



M2QA系列 变极多速三相异步电动机

公司简介

上海ABB电机有限公司成立于1995年12月，隶属于世界500强ABB集团，是专门生产和销售低压交流三相异步电动机（机座号71-355）的企业。

公司提供符合IEC标准的各种电机，可满足不同行业需求，其产品包括标准电机、变频电机、船用电机、隔爆电机、烟道电机、多速电机、制动电机、户外电机、无火花电机、铝壳电机、磨头电机。并提供按客户要求设计的特殊电机，所有设计均可达到客户的严格要求。同时，公司可提供具有不同绝缘等级，并能满足不同电压和频率要求的各种电机。公司主要OEM客户是空调风机、港机及起重机、泵业、减速机、机床、纺织机械、玻璃机械、船用、电厂辅机、电路板机械等行业领先企业。项目覆盖：电厂、制浆造纸、石化、冶金、船舶、港口、建筑、水泥、机场等。目前，公司生产的45%的电机通过ABB国际销售网络出口国外，主要是欧洲市场。

作为中国第一家获得ISO9001质量管理体系认证和ISO14001环境管理体系认证的中小型电机制造厂。上海ABB电机有限公司以其良好的管理和先进的技术，向客户提供世界顶级的ABB产品和服务。



Company Introduction

Founded in December 1995, ABB Shanghai Motors Co., Ltd., belongs to ABB Group, one of the world's Top 500 Corporations, and specializes in manufacturing and marketing low voltage AC 3-phase asynchronous motors of frame size from 71 to 355.

The company offers a wide range of IEC Standard motors to meet the demands of various industries, including Standard Motors, Frequency Conversion Motors, Marine Motors, Flameproof Motors, Smoke Venting Motors, Multi-speed Motors, Brake Motors, Outdoor Environment Motors, Non-sparking Motors, Aluminum Motors, and Motors for Glass Machinery, together with specially customized motors as per customers' demands and meeting customers' stringent requirements. In addition, the company can supply a broad range of motors with various insulation classes, which can meet various voltage and frequency requirements. The company major OEM customers are leaders in HVAC, crane, pump, gearbox, machine tool, textile, glass, marine, power plant auxiliary equipment, circuit board, etc. And its projects cover: power plant, pulp and paper, PEC, metal, marine, port, building, cement, airport, etc. Forty-five percent of its motors are currently exported abroad, mainly to the European market.

As the first small-medium motor manufacturer with ISO9001 Certification and ISO14001 Certification in China, ABB Shanghai Motors Co., Ltd. Provides its customers with world-class ABB products and service with qualified management and advanced technology.



目录 Content

ABB电机产品特点 ABB Product Features	4
M2QA系列突出特点 Outstanding Features of M2QA Motors	4
产品概述 Summary	5
标准 Standards	6
合理的结构设计 Mechanical Design	6
优越的电气性能 Electrical Design	6
众多的选择满足各种用户需求 Special Requirements Can be Supplied on Request	7
电动机型号说明 Type Designation	7
使用条件 Conditions of Operation	7
安装结构型式 Mounting Designation (IM)	7
订货须知 Ordering Information	8
产品代码说明 Explanation of the Product Code	8
电机技术数据表 Technical Data Table	9
电动机外形图 Dimension Drawing	18
轴承型号，接线盒出线孔尺寸 Type of Bearing Cable Entry	20
电机铭牌 Rating Plate	20
M2QA变极变速系列三相异步电动机变量代码 M2QA Variant Code	21

ABB电机产品特点 ABB Motors Features

可靠
High Reliability

高效
High Efficiency

一致
Excellent Consistency

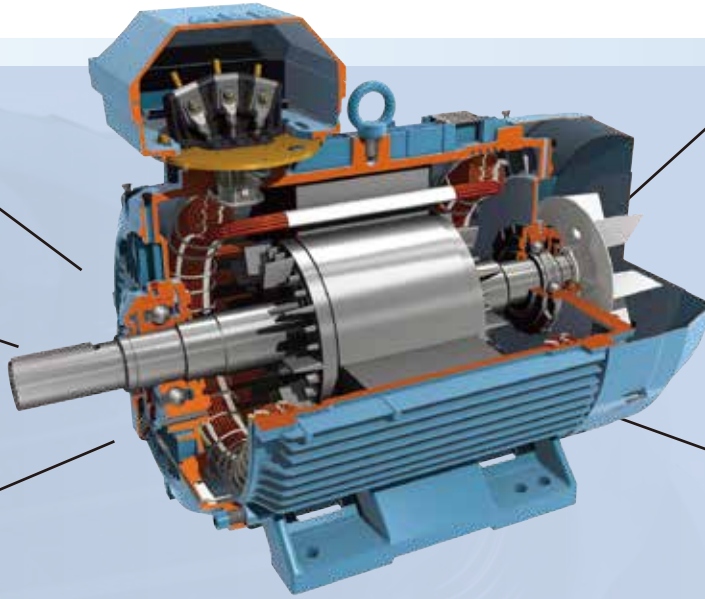

低噪音
Low Noise

高灵活性
High Flexibility

M2QA 系列突出特点

- ❖ 特殊设计，能够通过变极调速获得两种或两种以上不同的转速，简化变速系统，有效节约调速成本。
- ❖ 根据设备实际操作情况合理分配功率达到节约能耗的效果。

Outstanding Features of M2QA Motors

- ❖ By simple switching between the pole pairs, different motor speeds can be achieved.





产品概述

M2QA系列变极多速三相异步电动机（H80-H280）

M2QA系列变极多速三相异步电动机是M2QA系列电动机的电气派生产品，该系列电动机由于具有可随负载性质的要求实现变极调速。其安装和外形尺寸与相应的基本系列完全相同，在机床、矿山、冶金、纺织、印染、化工、农机等工业部门得到广泛的应用。



Summary

M2QA Series Pole Changing Multi-speed Three-phase Induction Motors (H80-H280)

Electrically derived from M2QA series motors, the M2QA series pole changing multi-speed three-phase induction motors can vary the motor speed by change of the pole pairs. The mounting arrangements and dimensions are the same as for the standard series motors. M2QA/QAD series motors are extensively used areas such as machine tooling, mining, metallurgical areas, textiles, dyeing, chemical and agricultural applications.

标准

1. 电机参照国际标准设计制造

- ❖ 国际电工委员会IEC60034、IEC60072
- ❖ 英国标准BS4999-5000
- ❖ 澳大利亚标准AS1359-2
- ❖ 德国标准DIN42673

2. 电机符合下列标准

- ❖ GB755
- ❖ GB10069
- ❖ Q/JBQS36

Standards

1. These motors are built to comply with current International Standards.

- ❖ International Electro-technical Commission-IEC60034 and IEC60072
- ❖ British Standard-BS5000 and BS4999
- ❖ Australian Standard-AS1359-2
- ❖ German Standard-DIN42673

2. These motors are built to comply with current National Standards

- ❖ GB755
- ❖ GB10069
- ❖ Q/JBQS36

合理的结构设计

- ❖ 灵活的引出线方向
电机接线盒的安装方式可在电机顶部、左侧、右侧各种形式，接线盒自身可旋转安装，71-132机座引出线可旋转 $4 \times 90^\circ$ 方向，160以上机座引出线可旋转 $2 \times 180^\circ$ 方向。用户在订货时无特殊说明，则电机按接线盒在顶部出线孔朝右方式供货。
- ❖ 美观的电机造型
机座散热筋设计成垂直、水平分布，端盖、接线盒、风罩均作改进设计，外形别致美观。

Mechanical Design

- ❖ Terminal boxes
Terminal boxes are mounted either on the top, or on either side of the motor. The terminal box of motors sizes 80 to 132 can be turned $4 \times 90^\circ$ and in motors sizes 160 to 280 rotated $2 \times 180^\circ$. To enable the supply of suitable terminations for the motor, please state cable type, quantity and size when ordering.
- ❖ Polished outward appearance
The external design of the motors is consistent with the design of the ABB "M2000" Family. The frame, cooling ribs, terminal box and fan cover have been reshaped to meet customer's design preference.

优越的电器性能

- ❖ 低噪声低振动
通过设计及工艺的改进，M2QA/QAD系列电机在噪声、振动上有了大幅度降低，并达到先进水平。
- ❖ 高性能的防护等级
电机的标准设计防护等级为IP55，可按用户要求提供更高要求的防护等级。
- ❖ 提高绝缘等级，增加电机使用寿命
标准电机采用F级绝缘结构，从而提高电机使用寿命，增加了电机可靠性。
- ❖ 高效率
电机采用优化设计，具有较高效率，可产生可观的节能效果。

Electrical Design

- ❖ Minimum Noise and Vibration levels
Careful attention to design and manufacturing details has allowed International Standards to be comfortably met.
- ❖ Maximum Degrees of Protection
All ABB motors are protected to IP55 as a minimum. Higher levels of protection are available on request.
- ❖ Class F insulation offers greater reliability and security.
- ❖ High Efficiency
M2QA/QAD motors are designed for high efficiency and low temperature rise giving a long service life and reduced running costs.

众多的选择满足各种用户需求

- ❖ 加装热敏电阻。
- ❖ 加装加热带。
- ❖ 加装注油嘴。
- ❖ 加装防尘密封圈（IP56）。
- ❖ 加装防油密封圈。
- ❖ 加装特殊法兰。
- ❖ 加装特殊轴伸等各种需求。

Special Requirements Can be Supplied on Request

- ❖ Thermistors
- ❖ Anti-condensation heaters
- ❖ Re-greasing facilities
- ❖ Dust-proof (IP56)
- ❖ Oil seals
- ❖ Non standard flanges
- ❖ Non standard shaft extensions

电动机型号说明 Type Designation

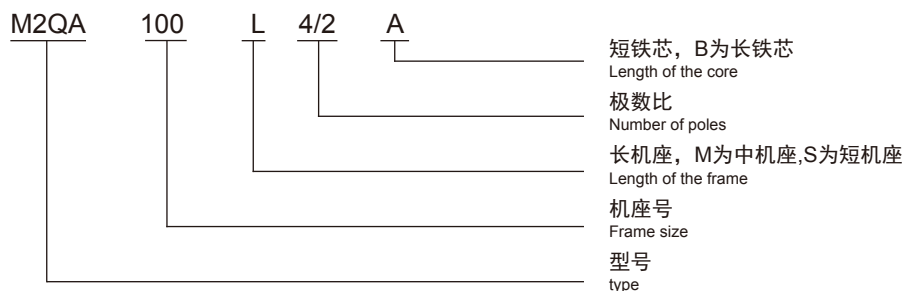

使用条件

- ❖ 海拔不超过1000m。
- ❖ 环境空气温度随季节而变化, 但不超过+40°C。
- ❖ 工作电压: 380V, 400V
- ❖ 额定频率: 50Hz
- ❖ 工作方式: 连续 (S1)
- ❖ 绝缘等级: F

Conditions of Operation

- ❖ An altitude should not be over 1,000 meters above sea level.
- ❖ An ambient temperature not exceeding +40°C.
- ❖ Voltage: 380V, 400V
- ❖ Frequency: 50Hz
- ❖ Duty: continuous (S1)
- ❖ Insulation class: F

安装结构型式

- ❖ B3机座带底脚, 端盖无凸缘。
- ❖ B5机座不带底脚, 端盖有凸缘。
- ❖ B35机座带底脚, 端盖有凸缘。

Mounting Designation(IM)

- ❖ B3 Foot-mounted motor
- ❖ B5 Flange-mounted motor
- ❖ B35 Foot-mounted and flange-mounted motor

基本结构形式 Fundamental arrangement			B3			
安装结构形式 Mounting arrangement	B3	B6	B7	B8	V5	V6
示意图 Diagram						
基本结构形式 Fundamental arrangement	B5			B35		
安装结构形式 Mounting arrangement	B5	V1	V3	B35	V15	V35
示意图 Diagram						

订货须知

订货举例

订购电动机时，请详细说明电动机型号、规格和产品代码。电动机的产品代码有不同的组成方法，下面列举一些例子。

A	B	C				-	D, E, F, G			
M2QA	100L4/2A	2QAD	10	8	5 11	-	A	S	A	X
		1-4	5-6	7	8-10	11	12	13	14	15

- A 电动机型号¹⁾
- B 电动机规格
- C 产品代码
- D 安装型式代码
- E 电压和频率代码
- F 产地代码

1) : 发票上显示的型号为M2QA(I)/M2QA(II)

Ordering Information

Sample order

When placing an order, the motor type, size and product code must be specified. The product code of the motor is composed in various ways, in accordance with the following examples.

- A Motor type¹⁾
- B Motor size
- C Product code
- D Mounting arrangement code
- E Voltage and frequency code
- F Generation code

产品代码说明

Explanation of the Product Code

第1位~第4位

Positions 1 and 4

2QAD/2QA2=M2QA系列变级多速三相异步电动机
2QAD/2QA2=M2QA Series Pole Changing Multi-speed
Three-phase Induction Motors

第5位~第6位

Positions 5 and 6

IEC机座号
IEC frame

08=80	13=132	22=225
09=90	16=160	25=250
10=100	18=180	28=280
11=112	20=200	

第7位

转速(极数)

8=双速
9=多速

Positions 7

Speed(pole pairs)

8=Two-speed motors
9=Multi-speed motors

第8位~第10位 编号

Positions 8 to 10

Running number series

第11位

-(破折号)

Positions 11

-(dash)

第12位

安装型式

A=底脚安装，接线盒顶置
R=底脚安装，接线盒右置（从驱动端看）
L=底脚安装，接线盒左置（从驱动端看）
B=大法兰安装
C=小法兰安装(80-160)
H=底脚和法兰安装

Positions 12

Mounting arrangement

A=Foot-mounted, top-mounted terminal box
R=Foot-mounted, terminal box on RHS, seen from D-end
L=Foot-mounted, terminal box on LHS, seen from D-end
B=Flange-mounted, large flange
C=Flange-mounted, small flange size(80-160)
H=Foot-and flange-mounted

第13位

电压和频率代码
见相应页上的表格

Positions 13

Voltage and frequency code
See tables on appropriate page

第14位

产地代码

A

Positions 14

Generation code

A

第15位

VC标识代码
X

Positions 15

VC Identifying code
X

电机技术数据表 Technical Data Table

IP55-IC411

Insulation class F
temperature rise class B

Motor Type	Output (kW)	Product code	Speed r/min	Efficiency %	Power factor	I _N A	Current		Torque			Sound pressure level Lp dB(A)	Moment of inertia J=1/4GD ² kgm ²	Weight kg
							I _s /I _N	T _N Nm	T _s T _N	T _{MAX} T _N				
1500/3000 r/min=4-2ploes				400V 50Hz			Fan drive, two separate windings							
M2QA 80M4-2A	0.14	2QA2 088321**A	1415	53	0.57	0.67	4	0.94	1.8	2.3	68	0.00095	16	
	0.65		2870	71.5	0.81	1.62	6.5	2.16	1.9	2.4				
80M4-2B	0.2	088322**A	1410	53.5	0.59	0.91	4	1.35	1.8	2.3	68	0.00101	16	
	0.95		2850	73	0.82	2.29	6.5	3.18	1.9	2.4				
80M4-2C	0.25	088323**A	1405	56.5	0.62	1.03	4	1.7	1.8	2.3	68	0.00117	17	
	1.1		2840	74	0.84	2.55	6.5	3.7	1.9	2.4				
90S4-2A	0.22	098121**A	1405	50	0.62	1.02	3.5	1.5	1.4	2.0	72	0.00135	20	
	1.4		2850	76.5	0.87	3.04	6.5	4.69	2.0	2.4				
90L4-2A	0.3	098521**A	1405	53	0.65	1.26	3.5	2.04	1.4	2.0	72	0.00163	23	
	1.9		2860	78	0.87	4.04	7.0	6.34	2.0	2.4				
100L4-2A	0.4	108521**A	1435	65	0.67	1.33	4.5	2.66	1.5	2.2	76	0.00402	31	
	2.5		2885	79.5	0.87	5.22	7.0	8.28	2.0	2.6				
112M4-2A	0.6	118321**A	1460	66	0.59	2.22	6.0	3.92	1.8	2.8	79	0.00671	38	
	3.5		2895	82	0.89	6.92	7.0	11.55	2.0	2.5				
132S4-2A	1	138121**A	1465	72	0.59	3.40	5.5	6.52	1.5	2.5	83	0.01442	53	
	5.5		2915	85	0.88	10.61	8.0	18.02	2.1	2.6				
132M4-2A	1.2	138321**A	1465	76.5	0.60	3.82	5.5	7.82	1.5	2.5	83	0.01618	64	
	7.4		2915	86.5	0.90	13.72	8.0	24.24	2.1	2.6				
160M4-2A	1.9	168321**A	1465	80	0.67	5.12	6.5	12.39	2.0	2.5	84	0.05122	118	
	13		2920	87	0.91	23.7	8.0	42.52	2.2	2.8				
160L4-2A	2.5	168521**A	1465	81	0.69	6.46	6.5	16.30	2.0	2.4	84	0.06782	139	
	17.5		2920	88	0.92	31.20	8.0	57.23	2.2	2.8				
180M4-2A	2.8	188321**A	1475	84	0.69	6.97	6.0	18.13	1.9	2.8	84	0.08805	165	
	20		2950	89	0.89	36.45	8.0	64.75	2.2	2.8				
180L4-2A	3.6	188521**A	1475	85	0.70	8.73	6.0	23.31	1.9	2.8	84	0.10442	188	
	25		2950	90	0.90	44.55	8.0	80.93	2.2	2.8				
200L4-2A	4.1	208521**A	1480	81	0.70	10.44	6.0	26.46	2.2	2.8	87	0.15611	232	
	30		2960	90.5	0.89	53.76	8.0	96.79	2.2	2.8				
200L4-2B	5.5	208522**A	1480	83	0.71	13.47	6.0	35.49	2.2	2.8	87	0.18287	268	
	38		2960	91	0.90	66.97	8.0	122.60	2.3	2.8				
225M4-2B	6	228322**A	1485	86.5	0.71	14.10	6.0	38.59	1.9	2.8	87	0.29345	335	
	43		2975	92	0.88	76.66	8.0	138.03	2.2	2.8				
225M4-2C	7	228323**A	1485	87	0.71	16.36	6.0	45.02	1.9	2.8	87	0.33299	362	
	50		2975	92.5	0.89	87.67	8.0	160.50	2.2	2.8				
250M4-2B	10	258322**A	1485	87.5	0.73	22.60	6.5	64.31	2.2	2.8	89	0.50876	458	
	70		2975	93	0.91	119.39	9.0	224.71	2.3	2.8				
1500/3000 r/min=4/2ploes				400V 50Hz			Fan drive, Dahlander-connection							
M2QA 80M4/2A	0.2	2QA2 088311**A	1395	57.5	0.65	0.77	3.5	1.37	1.4	1.9	68	0.00091	16	
	0.85		2835	75	0.85	1.92	6.0	2.86	1.8	2.2				
80M4/2B	0.25	088312**A	1410	64.5	0.62	0.90	3.5	1.69	1.5	1.9	68	0.11101	17	
	1.1		2840	77	0.85	2.43	6.0	3.70	2.0	2.4				
80M4/2C	0.35	088313**A	1400	66	0.66	1.16	3.5	2.39	1.5	1.9	68	0.00117	18	
	1.4		2830	77.5	0.85	3.07	6.0	4.72	2.0	2.4				
90S4/2A	0.33	098111**A	1410	62	0.57	1.35	3.5	2.24	1.6	2.1	72	0.00135	20	
	1.5		2855	78.5	0.86	3.21	7.0	5.02	2.2	2.5				
90L4/2A	0.45	098511**A	1420	66	0.53	1.86	4.0	3.03	2.0	2.1	72	0.00163	25	
	2.2		2865	81	0.86	4.56	7.5	7.33	2.4	2.7				
90L4/2B	0.47	098512**A	1425	67	0.50	2.03	4.0	3.15	2.0	2.1	72	0.00201	27	
	2.5		2865	82	0.87	5.06	7.5	8.33	2.4	2.7				
100L4/2A	0.6	108511**A	1445	74.5	0.61	1.91	5.0	3.97	1.5	2.1	76	0.00445	34	
	3		2875	83	0.89	5.86	7.5	9.97	2.0	2.4				
100L4/2B	0.7	108512**A	1445	75.5	0.63	2.12	5.0	4.63	1.5	2.1	76	0.00529	37	
	3.5		2870	83	0.90	6.76	7.5	11.65	2.0	2.4				
112M4/2A	1	118311**A	1445	81	0.82	2.17	6.5	6.61	2.0	2.8	79	0.01306	45	
	4.5		2850	82	0.88	9.00	7.5	15.08	2.4	2.8				
132S4/2A	1.3	138111**A	1460	82.5	0.69	3.30	6.5	8.50	2.1	2.8	83	0.01442	57	
	6.2		2905	86	0.90	11.56	7.5	20.38	2.3	2.8				
132M4/2A	1.7	138311**A	1460	85	0.72	4.01	6.5	11.12	2.1	2.8	83	0.1966	76	
	8.3		2910	87	0.92	14.97	8.0	27.24	2.3	2.8				

D
400V 50Hz

其他电压频率（最大值，690V）可通过添加VC002, VC209实现。（VC定义请见后页VC适用表）

Other rated voltage connection or frequency(Max,690V)can be used with VC002 or VC209,(The meaning of Variant code can be referred to Variant Code List)

电机技术数据表 Technical Data Table

IP55-IC411

Insulation class F
temperature rise class B

Motor Type	Output (kW)	Product code	Speed r/min	Efficiency %	Power factor	I _N A	Current		Torque		Sound pressure level Lp dB(A)	Moment of inertia J=1/4GD ² kgm ²	Weight kg
							I _s I _N	T _N Nm	T _s T _N	T _{MAX} T _N			
1500/3000 r/min=4/2ploys							400V 50Hz			Fan drive, Dahlandar-connection			
M2QA 160M4/2A	2	2QA2 168311**A	1460	84.5	0.68	5.02	6.0	13.08	2.4	2.3	84	0.0436	104
	10		2925	87	0.90	18.43	7.0	32.65	2.2	2.8			
160M4/2B	3.2	168312**A	1465	85.5	0.67	8.06	6.0	20.86	2.4	2.3	84	0.06091	139
	16		2925	88.5	0.91	28.68	7.0	52.24	2.2	2.8			
160L4/2A	4.5	168511**A	1460	86.5	0.70	10.73	6.0	29.43	2.2	2.3	84	0.07336	147
	19.5		2925	89	0.91	34.75	7.5	63.67	2.25	2.8			
180M4/2A	4.7	188311**A	1475	88	0.69	11.17	6.0	30.43	2.0	2.8	84	0.08805	165
	21.5		2950	90	0.90	38.31	7.5	69.60	2.0	2.8			
180L4/2A	5.2	188511**A	1475	89	0.69	12.22	6.0	33.67	2.0	2.8	84	0.10442	187
	26		2950	90.5	0.91	45.57	7.5	84.17	2.0	2.8			
200L4/2A	8	208511**A	1475	89.5	0.76	16.98	5.0	51.80	1.8	2.8	87	0.14821	231
	32		2960	90.5	0.89	57.35	7.5	103.24	2.2	2.8			
200L4/2B	10	208512**A	1475	90	0.76	21.10	5.0	64.75	1.9	2.8	87	0.18287	268
	39		2965	91.5	0.89	69.13	8.0	125.62	2.4	2.8			
200L4/2C	11	208513**A	1475	90.5	0.76	23.08	5.0	71.22	1.9	2.8	87	0.18845	281
	42		2965	91.5	0.89	74.44	8.0	135.28	2.5	2.8			
225M4/2B	13	228312**A	1480	91	0.77	26.78	5.0	83.89	1.6	2.3	87	0.29345	334
	45		2975	91.5	0.88	80.67	8.0	144.45	2.3	2.8			
225M4/2C	15	228313**A	1480	91.5	0.77	30.73	5.0	96.79	1.6	2.3	87	0.37254	376
	55		2975	92	0.89	96.95	8.0	176.55	2.3	2.8			
250M4/2B	25	258312**A	1480	91.5	0.79	49.92	5.0	161.32	1.4	2.5	89	0.48742	461
	75		2970	93	0.89	130.79	9.0	241.16	2.4	2.8			
750/1500 r/min=8-4ploys							400V 50Hz			Fan drive, two separate windings			
M2QA 80M8-4A	0.075	2QA2 088361**A	575	27	0.62	0.65	2.0	1.25	2.1	2.8	59	0.00145	16
	0.48		1390	62	0.73	1.53	4.0	3.29	1.8	2.2			
80M8-4B	0.1	088362**A	580	28.5	0.62	0.82	2.0	1.65	2.1	2.8	59	0.00164	17
	0.63		1360	63.5	0.79	1.81	4.0	4.42	1.8	2.2			
80M8-4C	0.12	088363**A	590	31	0.61	0.92	2.0	1.94	2.1	2.8	59	0.00183	18
	0.73		1355	64	0.80	2.06	4.0	5.15	1.8	2.2			
90S8-4A	0.13	098161**A	670	37	0.56	0.91	3.0	1.85	2.1	2.8	60	0.0028	23
	1		1400	71	0.80	2.54	5.5	6.82	1.9	2.4			
90L8-4A	0.18	098561**A	675	41	0.54	1.17	3.0	2.55	2.1	2.8	60	0.00356	27
	1.4		1400	73	0.82	3.38	5.5	9.55	1.9	2.4			
100L8-4A	0.25	108561**A	665	43	0.58	1.45	2.5	3.59	1.4	2.0	61	0.00741	34
	1.85		1430	76.5	0.80	4.36	6.0	12.35	1.9	2.4			
100L8-4B	0.33	108562**A	670	47.5	0.58	1.73	2.5	4.70	1.4	2.0	61	0.00862	38
	2.3		1430	77.5	0.81	5.29	6.0	15.36	1.9	2.4			
112M8-4A	0.4	118361**A	695	54	0.58	1.84	3.5	5.50	1.6	2.6	74	0.01306	45
	3		1425	79.5	0.85	6.41	6.5	20.11	2.0	2.5			
132S8-4A	0.6	138161**A	715	59	0.53	2.77	3.5	8.01	1.5	2.3	74	0.02673	56
	4		1440	81.5	0.83	8.54	6.5	26.62	2.3	2.6			
132M8-4A	0.9	138361**A	720	63.5	0.53	3.86	3.5	11.94	1.5	2.3	74	0.3432	68
	5.5		1440	83	0.83	11.52	7.0	36.48	2.3	2.6			
160M8-4A	1.3	168361**A	725	68.5	0.50	5.48	4.5	17.12	2.0	2.0	76	0.07302	115
	9		1460	86.5	0.85	17.67	7.5	58.87	2.5	2.8			
160L8-4A	1.8	168561**A	725	69.5	0.51	7.33	4.5	23.71	2.0	2.0	76	0.0975	136
	13		1460	87	0.86	25.08	7.5	85.03	2.5	2.8			
180M8-4A	2.3	188361**A	735	75.5	0.52	8.46	4.5	29.88	2.1	2.8	80	0.16049	170
	16		1470	88.5	0.86	30.34	7.5	103.95	2.2	2.8			
180L8-4A	2.7	188561**A	735	76	0.56	9.86	4.5	35.08	2.1	2.8	80	0.18046	186
	19		1470	89.5	0.86	36.05	7.5	123.04	2.4	2.8			
200L8-4A	3.3	208561**A	740	78	0.56	10.90	4.5	42.59	2.0	2.8	80	0.2819	254
	26		1475	90.5	0.85	48.79	7.5	168.34	2.3	2.8			
200L8-4B	3.8	208562**A	740	79	0.56	12.40	4.5	49.04	2.0	2.8	82	0.3073	271
	30		1475	91	0.87	54.70	7.5	194.24	2.2	2.8			
225M8-4B	5.2	228362**A	740	80.5	0.58	16.08	5.0	67.11	1.9	2.8	82	0.52731	332
	38		1480	91	0.87	69.28	7.5	245.20	2.2	2.8			
225M8-4C	7	228363**A	740	82	0.59	20.88	5.0	90.34	1.9	2.8	82	0.57253	385
	46		1480	92	0.88	82.01	7.5	296.82	2.3	2.8			
250M8-4B	10	258362**A	740	84.5	0.58	29.45	5.0	129.05	1.8	2.8	84	0.81668	499
	63		1480	92.5	0.86	114.31	8.0	406.52	2.6	2.8			

D
400V 50Hz

其他电压频率（最大值，690V）可通过添加VC002, VC209实现。（VC定义请见后页VC适用表）

Other rated voltage connection or frequency(Max,690V)can be used with VC002 or VC209,(The meaning of Variet code can be referred to Variant Code List)

电机技术数据表 Technical Data Table

IP55-IC411

Insulation class F
temperature rise class B

Motor Type	Output (kW)	Product code	Speed r/min	Efficiency %	Power factor	I _N A	Current		Torque			Sound pressure level Lp dB(A)	Moment of inertia J=1/4GD ² kgm ²	Weight kg
							I _s / I _N	T _N Nm	T _s / T _N	T _{MAX} / T _N				
750/1500 r/min=8/4p/oes				400V 50Hz			Fan drive, Dahlander-connection							
M2QA 80M8/4A	0.13	2QA2 088351**A	630	45.5	0.56	0.74	2.5	1.97	1.5	2.2	59	0.00145	16	
	0.55		1410	67	0.66	1.80	5.0	3.73	2.4	2.8				
80M8/4B	0.17	088352**A	650	50	0.54	0.91	2.5	2.50	1.5	2.2	59	0.00164	18	
	0.75		1415	70	0.67	2.31	5.0	5.06	2.4	2.8				
80M8/4C	0.2	088353**A	645	51	0.55	1.03	2.5	2.96	1.5	2.2	59	0.00183	19	
	0.9		1410	71	0.69	2.65	5.0	6.10	2.4	2.8				
90S8/4A	0.26	098151**A	680	51	0.56	1.31	2.5	3.65	1.5	2.4	60	0.00254	23	
	1.1		1390	75.5	0.84	2.50	5.5	7.56	2.0	2.3				
90L8/4A	0.35	098551**A	685	54.5	0.53	1.75	3.0	4.88	1.7	2.6	60	0.00356	27	
	1.7		1385	76.5	0.84	3.82	5.5	11.72	2.0	2.3				
90L8/4B	0.35	098552**A	690	55	0.51	1.80	3.0	4.84	1.7	2.6	60	0.00368	28	
	1.8		1385	77	0.81	4.02	5.5	12.41	2.0	2.3				
100L8/4A	0.5	108551**A	690	63	0.52	2.20	3.0	6.92	1.8	2.0	61	0.00832	36	
	2.3		1430	80.5	0.81	5.09	6.5	15.36	2.2	2.5				
100L8/4B	0.6	108552**A	690	63.5	0.53	2.57	3.0	8.30	1.8	2.0	61	0.00893	39	
	2.8		1430	81	0.81	6.20	6.5	18.70	2.2	2.5				
100L8/4C	0.65	108553**A	695	64.5	0.51	2.85	3.5	8.93	1.8	2.0	61	0.00954	41	
	3.0		1430	81.5	0.81	6.56	7.0	20.03	2.2	2.5				
112M8/4A	0.7	118351**A	710	70	0.53	2.72	4.0	9.42	2.2	2.8	74	0.01454	48	
	3.5		1435	82.5	0.84	7.29	6.5	23.29	2.4	2.8				
132S8/4A	1.0	138151**A	720	75.5	0.54	3.54	4.0	13.26	1.5	2.0	74	0.2673	63	
	5.0		1430	83.5	0.85	10.17	7.0	33.39	2.2	2.5				
132M8/4A	1.4	138351**A	720	77.5	0.54	4.83	4.0	18.57	1.5	2.0	74	0.0365	78	
	6.8		1440	85.5	0.85	13.51	7.5	45.10	2.2	2.5				
160M8/4A	2.2	168351**A	730	79.5	0.53	7.54	4.5	28.78	2.3	2.8	76	0.07302	119	
	10.5		1460	87	0.84	20.74	7.5	68.68	2.7	2.8				
160L8/4A	2.7	168551**A	735	80.5	0.50	9.68	4.5	35.28	2.5	2.8	76	0.1055	147	
	15.5		1460	88	0.86	29.56	7.5	101.39	2.7	2.8				
180M8/4A	3.4	188351**A	735	83	0.52	11.37	4.5	44.18	2.0	2.8	80	0.16049	169	
	17		1470	89.5	0.85	32.26	7.5	110.44	2.0	2.8				
180L8/4A	4.4	188551**A	735	84	0.51	14.83	4.5	57.17	2.1	2.8	80	0.1929	199	
	22		1475	90	0.85	41.51	7.5	142.44	2.2	2.8				
200L8/4A	6.5	208551**A	740	86.5	0.56	19.37	4.5	83.89	1.8	2.8	80	0.3073	270	
	29		1475	91	0.86	53.49	7.5	187.76	2.1	2.8				
200L8/4B	8.0	208552**A	740	87	0.56	23.70	4.5	103.24	1.8	2.8	82	0.3327	287	
	33		1480	91.5	0.85	61.24	7.5	212.94	2.3	2.8				
225M8/4B	10	228352**A	740	88.5	0.60	27.18	5.0	129.05	1.7	2.8	82	0.48252	352	
	42		1480	91.5	0.87	76.16	8.0	271.01	2.4	2.8				
225M8/4C	11	228353**A	740	89	0.59	30.24	5.0	141.96	1.8	2.8	82	0.66901	395	
	50		1480	92	0.87	90.17	8.0	322.64	2.4	2.8				
250M8/4B	15	258352**A	740	89	0.59	41.23	4.5	193.58	1.7	2.8	84	0.78	473	
	60		1480	92.5	0.85	110.15	8.5	387.16	2.6	2.8				
1000/1500 r/min=6-4p/oes				400V 50Hz			Fan drive, two separate windings							
M2QA 80M6-4A	0.19	2QA2 088341**A	900	48	0.68	0.84	3.0	2.02	1.2	2.0	59	0.00145	16	
	0.5		1385	62	0.76	1.53	4.0	3.45	1.4	2.0				
80M6-4B	0.25	088342**A	900	49	0.69	1.07	3.0	2.65	1.2	2.0	59	0.00174	17	
	0.66		1390	65.5	0.78	1.86	4.0	4.53	1.4	2.0				
80M6-4C	0.3	088343**A	900	52	0.70	1.19	3.0	3.18	1.2	2.0	59	0.00193	20	
	0.78		1390	67.5	0.79	2.11	4.0	5.36	1.4	2.0				
90S6-4A	0.3	097141**A	920	58.5	0.72	1.03	3.5	3.11	1.4	2.2	60	0.0028	23	
	1.0		1400	71	0.80	2.54	5.5	6.82	1.9	2.4				
90L6-4A	0.45	098541**A	920	59	0.73	1.51	3.5	4.67	1.4	2.2	60	0.22356	27	
	1.5		1395	73.5	0.82	3.59	5.5	10.27	1.9	2.4				
100L6-4A	0.6	108541**A	930	61	0.71	2.00	3.5	6.16	1.3	1.8	61	0.007401	33	
	2.0		1420	76.5	0.82	4.60	5.5	13.45	1.9	2.2				
100L6-4B	0.8	108542**A	930	63.5	0.71	5.56	4.0	8.22	1.3	1.8	61	0.00862	39	
	2.5		1425	78	0.82	5.64	6.0	16.75	1.8	2.2				
112M6-4A	1.0	118341**A	950	69	0.68	3.08	4.5	10.05	1.7	2.6	66	0.01306	45	
	3.0		1425	79.5	0.85	6.41	6.5	20.11	2.0	2.5				
132S6-4A	1.5	138141**A	965	74.5	0.65	4.47	5.0	14.84	2.0	2.6	74	0.02673	60	
	4.5		1435	82.5	0.84	9.37	6.5	29.95	2.4	2.6				

D
400V 50Hz

其他电压频率（最大值，690V）可通过添加VC002，VC209实现。（VC定义请见后页VC适用表）

Other rated voltage connection or frequency(Max,690V)can be used with VC002 or VC209,(The meaning of Variant code can be referred to Variant Code List)

电机技术数据表 Technical Data Table

IP55-IC411

Insulation class F
temperature rise class B

Motor Type	Output (kW)	Product code	Speed r/min	Effi- ciency %	Power factor	IN A	Current		Torque			Sound pressur level Lp dB(A)	Moment of inertia J=1/4GD ² kgm ²	Weight kg
							I _s IN	T _N Nm	T _s T _N	T _{MAX} T _N				
1000/1500 r/min=6-4ploes				400V 50Hz				Fan drive, separate windings						
M2QA 132M6-4A	2.0	2QA2 138341**A	965	75.5	0.65	5.88	5.0	19.79	2.0	2.6	74	0.03432	69	
	6.0		1435	83.5	0.85	12.20	6.5	39.93	2.4	2.6				
160M6-4A	3.5	168341**A	980	79.5	0.71	8.95	6.0	34.11	1.6	2.4	76	0.07681	112	
	10.5		1465	86.5	0.85	20.61	8.0	68.45	2.2	2.6				
160L6-4A	4.5	168541**A	980	81	0.72	11.14	6.0	43.85	1.6	2.4	76	0.1055	128	
	14.5		1465	87.5	0.87	27.49	8.0	94.52	2.3	2.5				
180M6-4A	5.0	188341**A	985	83.5	0.75	11.52	7.0	48.48	1.8	2.8	80	0.16049	161	
	16		1470	88.5	0.89	29.32	8.0	103.59	1.9	2.3				
180L6-4A	6.5	188541**A	985	84.5	0.77	14.42	7.0	63.02	1.8	2.8	80	0.1929	184	
	20		1470	89.5	0.89	36.24	8.0	129.49	2.0	2.3				
200L6-4A	7.2	208541**A	985	84	0.72	17.18	6.0	70.16	1.8	2.8	80	0.26921	230	
	23		1475	89.5	0.87	42.64	7.5	149.93	2.4	2.8				
200L6-4B	9.0	208542**A	985	85	0.73	20.94	6.5	87.70	1.8	2.8	82	0.3073	259	
	30		1470	90.5	0.87	55.00	7.5	195.56	2.4	2.8				
225M6-4B	11	228342**A	985	85	0.86	21.72	6.5	106.65	1.6	2.7	82	0.47605	359	
	34		1475	90.5	0.88	61.62	7.5	220.14	2.2	2.8				
225M6-4C	14	228343**A	985	86	0.86	27.32	7.0	135.74	1.8	2.8	82	0.57253	401	
	42		1475	91	0.88	75.70	7.5	271.93	2.2	2.8				
250M6-4B	18.5	258342**A	990	87.5	0.82	37.22	8.0	178.46	2.1	2.8	88	0.81668	509	
	63		1480	92.5	0.89	110.46	8.0	406.52	2.4	2.8				
750/1000 r/min=8-6ploes				400V 50Hz				Fan drive, two separate windings						
M2QA 80M8-6A	0.1	2QA2 088381**A	640	32	0.55	0.82	2.5	1.49	1.5	2.5	59	0.00168	18	
	0.25		910	52	0.66	1.05	3.0	2.62	1.4	2.2				
80M8-6B	0.14	088382**A	635	35	0.59	0.98	2.5	2.11	1.5	2.5	59	0.00206	20	
	0.33		925	53	0.66	1.36	3.0	3.46	1.4	2.2				
90S8-6A	0.2	098181**A	650	44.5	0.67	0.97	2.5	2.94	1.4	2.1	60	0.00277	22	
	0.45		925	62	0.71	1.48	4.0	4.65	1.7	2.4				
90L8-6A	0.3	098581**A	660	50.5	0.65	1.32	2.5	4.34	1.4	2.1	60	0.00356	29	
	0.7		925	65	0.72	2.16	4.0	7.23	1.7	2.4				
100L8-6A	0.4	108581**A	695	54.5	0.60	1.77	3.0	5.50	1.3	2.0	61	0.00948	31	
	0.9		940	68	0.74	2.58	4.5	9.14	1.4	2.0				
100L8-6B	0.5	108582**A	695	55	0.61	2.15	3.0	6.87	1.3	2.0	61	0.01103	34	
	1.2		940	70.5	0.75	3.28	4.5	12.19	1.4	2.0				
200L8-6B	7.5	208582**A	735	82.5	0.70	18.75	6.5	97.45	2.0	2.8	78	0.41127	242	
	17		980	87.5	0.86	32.61	7.5	165.66	2.0	2.8				
200L8-6C	9.0	208583**A	735	83.5	0.70	22.23	7.0	116.94	2.1	2.8	78	0.47084	275	
	20		980	88.5	0.85	38.38	8.5	194.90	2.4	2.8				
225M8-6B	12	228382**A	740	87	0.72	27.65	7.0	154.86	2.4	2.8	76	0.65907	323	
	26		985	90.5	0.84	49.37	8.0	252.08	2.6	2.8				
225M8-6C	14	228383**A	740	87.5	0.75	30.79	7.0	180.68	2.2	2.8	76	0.7506	366	
	32		985	91	0.85	59.71	8.0	310.25	2.6	2.8				
250M8-6B	15	258382**A	740	87.5	0.69	35.86	7.5	193.58	2.8	2.8	79	1.43963	484	
	43		920	91.5	0.87	77.97	7.5	419.03	2.5	2.8				
500/1000 r/min=12/6ploes				400V 50Hz				Fan drive, Dahlandar-connection						
M2QA 90S12/6A	0.08	2QA2 098191**A	380	32.5	0.54	0.66	2.0	2.01	1.8	2.4	60	0.00324	22	
	0.5		920	66	0.71	1.54	4.0	5.19	1.6	2.2				
90L12/6A	0.12	098591**A	400	37.5	0.51	0.91	2.0	2.87	1.8	2.4	60	0.00434	28	
	0.75		925	68.5	0.72	2.19	4.0	7.74	1.6	2.2				
100L12/6A	0.16	108591**A	430	45	0.49	1.05	2.5	3.55	1.2	1.8	61	0.01103	32	
	0.9		950	71.5	0.72	2.52	4.5	9.05	1.3	1.7				
100L12/6B	0.2	108592**A	445	50	0.47	1.23	2.5	4.29	1.2	1.8	61	0.0131	38	
	1.3		945	72.5	0.73	3.55	4.5	13.14	1.3	1.7				

D
400V 50Hz

其他电压频率（最大值，690V）可通过添加VC002, VC209实现。（VC定义
请见后页VC适用表）

Other rated voltage connection or frequency(Max,690V)can be used with VC002
or VC209,(The meaning of Variet code can be referred to Variant Code List)

电动机外形图 Dimension Drawing

three phase motor, foot mounted, terminal box top-mounted

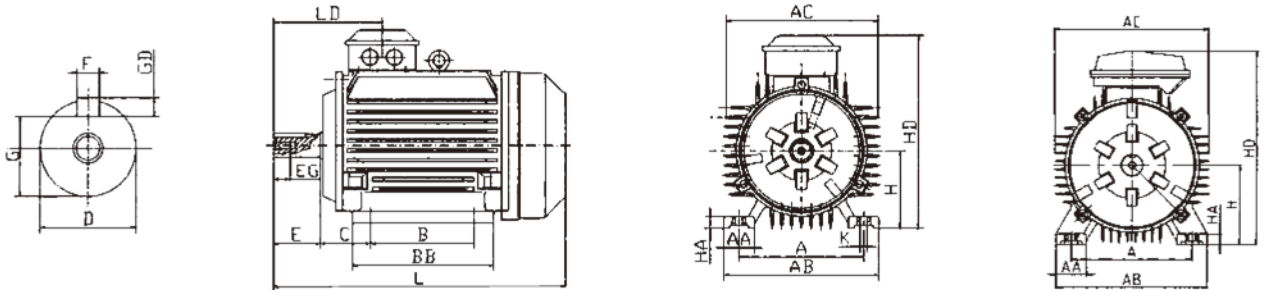

three phase motor, foot mounted, terminal box on right hand side

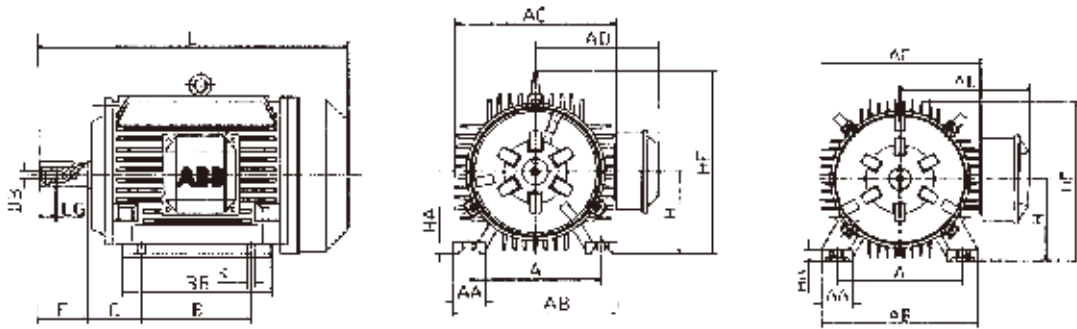

Type M2QA, QAD	A	AA	AB	AC	B	BB	C	D	E	F	G	GD	DB	EG
80M	125	35	160	165	100	135	50	19	40	6	15.5	6	M6	16
90S	140	35	175	180	100	140	56	24	50	8	20	7	M8	19
90L	140	35	175	180	125	165	56	24	50	8	20	7	M8	19
100L	160	40	200	205	140	180	63	28	60	8	24	7	M10	22
112M	190	50	240	225	140	190	70	28	60	8	24	7	M10	22
132S	216	55	270	265	140	205	89	38	80	10	33	8	M12	28
132M	216	55	270	265	178	240	89	38	80	10	33	8	M12	28
160M	254	60	325	330	210	265	108	42	110	12	37	8	M16	36
160L	254	60	325	330	254	310	108	42	110	12	37	8	M16	36
180M	279	70	350	355	241	315	121	48	110	14	42.5	9	M16	36
180L	279	70	350	355	279	350	121	48	110	14	42.5	9	M16	36
200L	318	70	390	395	305	380	133	55	110	16	49	10	M20	39
225S	356	75	435	440	286	380	149	60	140	18	53	11	M20	39
225M	356	75	435	440	311	405	149	60	140	18	53	11	M20	39
250M	406	80	490	515	349	455	168	65	140	18	58	11	M20	39
280S	457	85	555	540	368	490	190	75	140	20	67.5	12	M20	39
280M	457	85	555	540	419	540	190	75	140	20	67.5	12	M20	39

注：产品代码为2QAD电机无DB螺孔。 2QAD motors without DB screw hole

电机技术数据表 Technical Data Table

IP55-IC411

Insulation class F
temperature rise class B

380V50Hz														
Type designation	Output (kW)	Product code	Speed r/min	Efficiency Full load 100% η	Power factor cos ϕ	Current		Torque			Moment of inertia J=1/4GD ² kgm ²	Weight kg	Sound pressur level Lp dB(A)	
						I _N A	I _s I _N	T _N Nm	T _s T _N	T _{MAX} T _N				
M2QA 80M4/2A	0.45	2QAD 088311-**A	1430	66	0.74	1.40	6.5	3.01	1.5	1.8	0.00153	17	71	
	0.55		2810	65	0.87	1.48	7.0	1.87	1.7	1.8				
80M4/2B	0.55	088312-**A	1430	67	0.73	1.71	6.5	3.67	1.6	1.8	0.00183	18	71	
	0.75		2800	66	0.90	1.92	7.0	2.56	1.8	1.8				
90S4/2A	0.85	098111-**A	1420	74	0.76	2.30	6.5	5.72	1.8	1.8	0.00268	22	71	
	1.1		2860	71	0.85	2.77	7.0	3.67	1.9	1.8				
90L4/2A	1.3	098511-**A	1410	75	0.80	3.29	6.5	8.80	1.8	1.8	0.00348	26	75	
	1.8		2830	73	0.89	4.21	7.0	6.07	2.0	1.8				
100L4/2A	2	108511-**A	1430	79	0.81	4.75	6.5	13.36	1.7	1.8	0.00683	33	79	
	2.4		2860	77	0.89	5.32	7.0	8.01	1.9	1.8				
100L4/2B	2.4	108512-**A	1420	79	0.83	5.56	6.5	16.14	1.6	1.8	0.00891	39	79	
	3		2880	77	0.90	6.58	7.0	9.95	1.7	1.8				
112M4/2A	3.3	118211-**A	1440	82	0.83	7.37	6.5	21.89	1.9	1.8	0.01289	45	79	
	4		2890	79	0.90	8.55	7.0	13.22	2.0	1.8				
132S4/2A	4.5	138111-**A	1440	83	0.84	9.81	6.5	29.84	1.7	1.8	0.02728	62	83	
	5.5		2830	79	0.90	11.75	7.0	18.56	1.8	1.8				
132M4/2A	6.5	138311-**A	1450	84	0.85	13.83	6.5	42.81	1.7	1.8	0.03470	84	83	
	8		2830	80	0.90	16.88	7.0	27.00	1.8	1.8				
160M4/2A	9	168311-**A	1460	87	0.85	18.49	6.5	58.87	1.6	1.8	0.07961	130	87	
	11		2930	82	0.89	22.90	7.0	35.85	1.8	1.8				
160L4/2A	11	168511-**A	1470	87	0.86	22.34	6.5	71.46	1.7	1.8	0.09555	142	87	
	14		2940	82	0.90	28.82	7.0	45.48	1.9	1.8				
180M4/2A	15	188311-**A	1470	89	0.87	29.43	6.5	97.45	1.8	1.8	0.16096	175	87	
	18.5		2950	85	0.90	36.74	7.0	59.89	1.9	1.8				
180L4/2A	18.5	188511-**A	1470	89	0.88	35.89	6.5	120.19	1.6	1.8	0.18427	190	87	
	22		2910	86	0.91	42.71	7.0	72.20	1.8	1.8				
200L4/2A	26	208511-**A	1470	89	0.89	49.87	6.5	168.91	1.4	1.8	0.30574	268	90	
	30		2970	85	0.92	58.29	7.0	96.46	1.6	1.8				
225S4/2A	32	228111-**A	1470	90	0.89	60.70	6.5	207.89	1.4	1.8	0.59189	359	90	
	37		2970	86	0.92	71.05	7.0	118.97	1.6	1.8				
225M4/2A	37	228311-**A	1470	91	0.89	69.41	6.5	240.37	1.6	1.8	0.67029	391	90	
	45		2970	86	0.92	86.42	7.0	144.70	1.6	1.8				
250M4/2A	45	258311-**A	1470	91	0.89	84.42	6.5	292.35	1.6	1.8	0.80420	456	92	
	52		2970	87	0.92	98.71	7.0	167.21	1.6	1.8				
280S4/2A	60	288111-**A	1470	91	0.90	111.31	6.5	389.80	1.4	1.8	1.40352	619	92	
	72		2970	88	0.92	135.12	7.0	231.52	1.5	1.8				
280M4/2A	72	288311-**A	1470	91	0.90	133.57	6.5	467.76	1.4	1.8	1.69752	681	94	
	82		2970	88	0.93	152.24	7.0	263.67	1.5	1.8				
80M6-4A	0.15	088341-**A	910	49	0.65	0.72	4.0	1.57	1.5	1.8	0.00157	17	62	
	0.22		1420	57	0.77	0.76	5.0	1.48	1.5	1.8				
80M6-4B	0.22	088342-**A	910	54	0.65	0.95	4.0	2.31	1.5	1.8	0.00194	20	62	
	0.35		1420	64	0.77	1.08	5.0	2.35	1.5	1.8				
90S6/4A	0.65	098131-**A	920	67	0.72	2.05	6.0	6.75	1.6	1.8	0.00332	23	63	
	0.85		1400	70	0.79	2.34	6.5	5.80	1.5	1.8				
90L6/4A	0.85	098531-**A	910	68	0.73	2.60	6.0	8.92	1.6	1.8	0.00416	27	63	
	1.1		1400	73	0.79	2.90	6.5	7.50	1.5	1.8				
100L6/4A	1.3	108531-**A	940	73	0.71	3.81	6.0	13.21	1.7	1.8	0.00795	36	64	
	1.8		1430	77	0.82	4.33	6.5	12.02	1.5	1.8				
100L6/4B	1.5	108532-**A	940	75	0.70	4.34	6.0	15.24	1.6	1.8	0.00909	39	64	
	2.2		1420	77	0.80	5.43	6.5	14.80	1.5	1.8				
100L6-4C	0.9	108543-**A	960	68	0.64	3.14	5.0	8.95	1.6	1.8	0.00695	33	67	
	1.3		1450	74	0.77	3.47	6.0	8.56	1.6	1.8				
112M6/4A	2.2	118331-**A	940	77	0.75	5.79	6.0	22.35	1.7	1.8	0.01309	45	66	
	2.8		1430	81	0.82	6.41	6.5	18.70	1.6	1.8				

B
380V 50Hz

其他电压频率（最大值，690V）可通过添加VC002，VC209实现。（VC定义请见后页VC适用表）

Other rated voltage connection or frequency(Max,690V)can be used with VC002 or VC209,(The meaning of Variant code can be referred to Variant Code List)

电机技术数据表 Technical Data Table

IP55-IC411

Insulation class F
temperature rise class B

380V50Hz															
Type designation	Output (kW)	Product code	Speed r/min	Efficiency Full load 100% η	Power factor cos ϕ	Current		Torque			Moment of inertia J=1/4GD ² kgm ²	Weight kg	Sound pressur level Lp dB(A)		
						I _N A	I _s I _N	T _N Nm	T _s T _N	T _{MAX} T _N					
M2QA 132S6/4A	3	2QAD 138131-**A	940	79	0.75	7.69	6.0	30.48	1.5	1.8	0.02829	61	74		
	4		1440	80	0.82	9.26	6.5	26.53	1.7	1.8					
132M6/4A	4	138331-**A	960	82	0.75	9.88	6.0	39.79	1.6	1.8	0.03597	74	74		
	5.5		1450	82	0.86	11.85	6.5	36.22	1.6	1.8					
160M6/4A	6.5	168331-**A	910	84	0.78	15.07	6.0	68.21	1.5	1.8	0.07495	123	78		
	8		1470	82	0.84	17.65	6.5	51.97	1.5	1.8					
160L6/4A	9	168531-**A	910	85	0.78	20.63	6.0	94.45	1.6	1.8	0.09508	139	78		
	11		1470	83	0.85	23.69	6.5	71.46	1.7	1.8					
180M6/4A	11	188331-**A	970	85	0.76	25.87	6.0	108.30	1.6	1.8	0.26150	175	82		
	14		1460	84	0.85	29.79	6.5	91.58	1.7	1.8					
180L6/4A	13	188531-**A	970	86	0.78	29.45	6.0	127.99	1.7	1.8	0.30029	193	82		
	16		1460	85	0.85	33.65	6.5	104.66	1.7	1.8					
200L6/4A	18.5	208531-**A	980	87	0.78	41.42	6.5	180.28	1.6	1.8	0.50320	270	82		
	22		1430	86.5	0.86	44.93	7.0	146.92	1.5	1.8					
225S6/4A	22	228131-**A	930	88	0.86	44.17	6.5	225.91	1.8	1.8	0.78781	379	84		
	28		1390	86.5	0.87	56.53	7.0	192.37	1.8	1.8					
225M6/4A	26	228331-**A	920	88	0.86	52.20	6.5	269.89	1.8	1.8	0.88477	410	84		
	32		1390	85.5	0.90	63.18	7.0	219.86	1.8	1.8					
250M6/4A	32	258331-**A	960	90	0.87	62.10	6.5	318.33	1.4	1.8	1.33041	529	90		
	42		1460	88	0.91	79.69	7.0	274.73	1.3	1.8					
280S6/4A	42	288131-**A	960	90	0.87	81.50	6.5	417.81	1.5	1.8	2.26181	642	90		
	55		1470	87	0.9	106.73	7.0	357.31	1.3	1.8					
280M6/4A	55	288331-**A	960	90	0.87	106.73	6.5	547.14	1.6	1.8	2.84819	736	90		
	67		1470	87	0.89	131.47	7.0	435.27	1.3	1.8					
80M8/4B	0.27	088352-**A	710	47	0.55	1.59	4.5	3.63	1.4	1.8	0.00183	18	62		
	0.4		1420	65	0.73	1.28	5.5	2.69	1.4	1.8					
90S8/4A	0.37	098151-**A	710	54	0.57	1.83	5.0	4.98	1.5	1.8	0.00325	22	70		
	0.65		1400	70	0.87	1.62	6.0	4.43	1.5	1.8					
90L8/4A	0.45	098551-**A	690	58	0.63	1.87	5.5	6.23	1.6	1.8	0.00402	27	67		
	0.75		1390	72	0.87	1.82	6.5	4.95	1.5	1.8					
100L8/4A	0.85	108551-**A	710	67	0.63	3.06	5.5	11.43	1.6	1.8	0.01362	38	70		
	1.5		1420	74	0.88	3.50	6.5	10.09	1.4	1.8					
112M8/4A	1.5	118351-**A	720	72	0.60	5.28	5.5	19.90	1.7	1.8	0.17297	45	74		
	2.4		1440	78	0.88	5.31	6.5	15.92	1.7	1.8					
132S8/4A	2.2	138151-**A	720	75	0.64	6.96	5.5	29.18	1.5	1.8	0.04331	60	74		
	3.3		1440	80	0.88	7.12	6.5	21.89	1.7	1.8					
132M8/4A	3	138351-**A	720	78	0.65	8.99	5.5	39.79	1.5	1.8	0.06376	81	74		
	4.5		1440	82	0.89	9.37	6.5	29.84	1.6	1.8					
160M8/4A	5	168351-**A	730	82	0.65	14.25	5.5	65.41	1.5	1.8	0.10867	128	78		
	7.5		1450	87	0.90	14.55	6.5	49.40	1.6	1.8					
160L8/4A	7	168551-**A	730	84	0.66	19.18	5.5	91.58	1.5	1.8	0.13323	142	78		
	11		1450	87	0.89	21.58	6.5	72.45	1.6	1.8					
180L8/4A	11	188551-**A	730	87	0.72	26.68	6.0	143.90	1.5	1.8	0.30462	212	82		
	17		1460	88	0.91	32.25	7.0	111.20	1.5	1.8					
200L8/4A	14	208551-**A	730	87	0.74	33.04	6.0	183.15	1.8	1.8	0.47842	253	82		
	22		1470	88	0.92	41.29	7.0	142.93	1.7	1.8					
200L8/4B	17	208552-**A	730	87	0.74	40.12	6.0	222.40	1.5	1.8	0.58451	294	84		
	26		1470	88	0.92	48.79	7.0	142.70	1.7	1.8					
225M8/4A	24	228351-**A	730	89	0.77	53.21	6.0	313.97	1.5	1.8	0.82047	373	84		
	34		1470	88	0.88	66.71	7.0	220.88	1.5	1.8					
250M8/4A	30	258551-**A	740	90	0.78	64.93	6.0	387.16	1.6	1.8	1.33041	516	86		
	42		1480	89	0.91	78.79	7.0	271.01	1.7	1.8					

B
380V 50Hz

其他电压频率（最大值，690V）可通过添加VC002, VC209实现。（VC定义请见后页VC适用表）

Other rated voltage connection or frequency(Max,690V)can be used with VC002 or VC209,(The meaning of Variet code can be referred to Variant Code List)

电动机外形图 Dimension Drawing

three phase motor, foot-and flange-mounted, terminal box mounted on right hand side

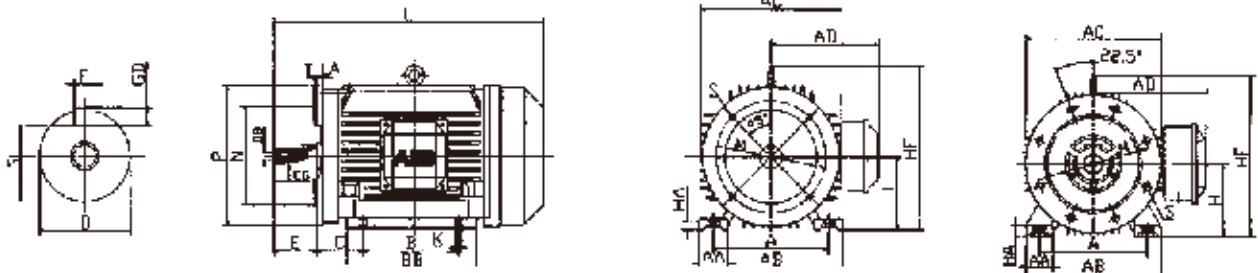

three phase motor, foot-and flange-mounted, terminal box top-mounted

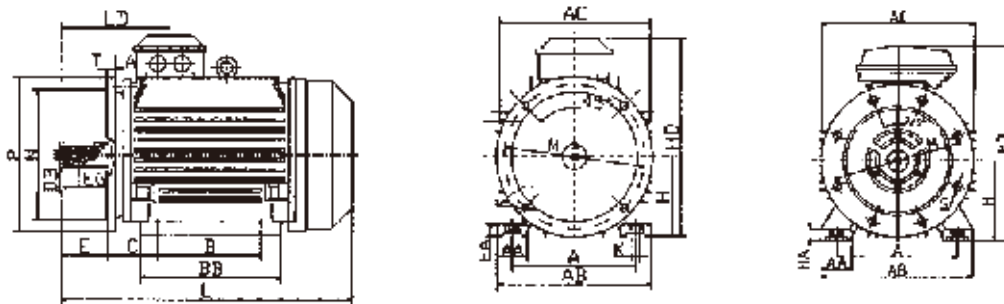

three phase motor, flange mounted

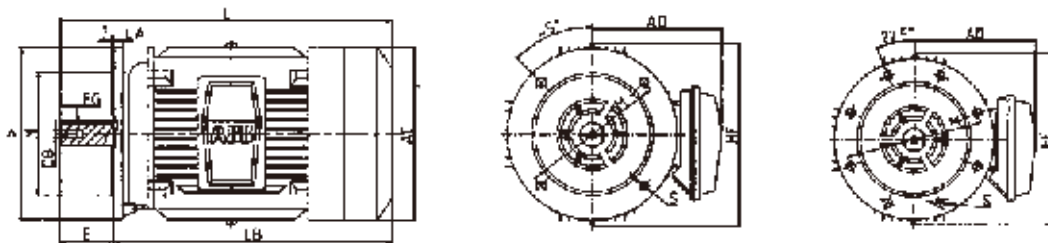

Type M2QA, QAD	H	HA	HD	HF	K	L	LD	AD	LA	M	N	P	S	T	HE
80M	80	12	225	170	10	285	116	145	9	165	130	200	12	3.5	200
90S	90	12	240	185	10	310	128	150	10	165	130	200	12	3.5	200
90L	90	12	240	185	10	335	128	150	10	165	130	200	12	3.5	200
100L	100	14	275	245	12	380	138	175	11	215	180	250	15	4	270
112M	112	15	290	265	12	395	144	185	11	215	180	250	15	4	278
132S	132	18	335	300	12	465	169	205	12	265	230	300	15	4	320
132M	132	18	335	300	12	505	169	205	12	265	230	300	15	4	320
160M	160	22	420	380	15	600	250	260	15	300	250	350	19	5	400
160L	160	22	420	380	15	645	250	260	15	300	250	350	19	5	400
180M	180	22	455	420	15	670	270	275	18	300	250	350	19	5	420
180L	180	22	455	420	15	710	270	275	18	300	250	350	19	5	420
200L	200	25	530	470	19	770	285	325	20	350	300	400	19	5	470
225S	225	28	580	520	19	820	340	355	20	400	350	450	19	5	520
225M	225	28	580	520	19	840	340	355	20	400	350	450	19	5	520
250M	250	30	645	580	24	930	360	375	22	500	450	550	19	5	655
280S	280	35	715	645	24	975	355	415	22	500	450	550	19	5	725
280M	280	35	715	645	24	1040	355	415	22	500	450	550	19	5	725

注：产品代码为2QAD电机无DB螺孔。 2QAD motors without DB screw hole

电机技术数据表 Technical Data Table

IP55-IC411

Insulation class F
temperature rise class B

380V50Hz														
Type designation	Output (kW)	Product code	Speed r/min	Efficiency Full load 100% η	Power factor $\cos\phi$	Current		Torque			Moment of inertia $J=1/4GD^2$ kgm ²	Weight kg	Sound pressure level Lp dB(A)	
						I _N A	I _s I _N	T _N Nm	T _s T _N	T _{MAX} T _N				
M2QA 280S8/4A	40	2QAD 288151-**A	730	91	0.80	83.48	6.0	523.29	1.6	1.8	1.97690	596	90	
	55		1470	90	0.91	102.03	7.0	357.31	1.7	1.8				
280M8/4A	47	288351-**A	730	91	0.81	96.8	6.0	614.86	1.6	1.8	2.66176	719	90	
	67		1470	90	0.92	122.95	7.0	435.27	1.7	1.8				
90S8/6A	0.35	098171-**A	700	56	0.60	1.58	5.0	4.78	1.8	1.8	0.00325	22	65	
	0.45		940	70	0.72	1.36	6.0	4.57	2	1.8				
90L8/6A	0.45	098571-**A	700	59	0.60	1.93	5.0	6.14	1.7	1.8	0.00402	27	65	
	0.65		930	71	0.73	1.91	6.0	6.67	1.8	1.8				
100L8/6A	0.75	108571-**A	720	65	0.60	2.92	5.0	9.95	1.8	1.8	0.01208	35	65	
	1.1		950	75	0.73	3.05	6.0	11.06	1.9	1.8				
112M8/6A	1.3	118371-**A	720	72	0.61	4.50	5.0	17.24	1.7	1.8	0.01730	45	67	
	1.8		950	78	0.73	4.80	6.0	18.09	1.9	1.8				
132S8/6A	1.8	138171-**A	720	76	0.62	5.80	5.0	23.88	1.6	1.8	0.04051	60	71	
	2.4		960	80	0.73	6.24	6.0	23.88	1.9	1.8				
132M8/6A	2.6	138371-**A	720	78	0.62	8.17	5.0	34.49	1.9	1.8	0.51474	73	71	
	3.7		960	82	0.73	9.39	6.0	36.81	1.9	1.8				
160M8/6A	4.5	168371-**A	730	82	0.62	13.45	5.0	58.87	1.6	1.8	0.09630	121	75	
	6		980	83	0.65	16.90	6.0	58.47	1.9	1.8				
160L8/6A	6	168571-**A	730	82	0.62	17.90	5.0	78.49	1.6	1.8	0.13030	137	75	
	8		980	86	0.70	20.20	6.0	77.96	1.9	1.8				
180M8/6A	7.5	188371-**A	730	84	0.62	21.88	5.0	98.12	1.9	1.8	0.26150	173	75	
	10		970	86	0.73	24.20	6.0	98.45	1.9	1.8				
180L8/6A	9	188571-**A	730	85	0.65	24.75	5.0	117.74	1.8	1.8	0.30029	191	75	
	12		970	86	0.75	28.27	6.0	118.14	1.8	1.8				
200L8/6A	12	208571-**A	730	86	0.65	32.62	5.0	156.99	1.8	1.8	0.50319	267	80	
	17		980	87	0.76	39.06	6.0	165.66	2	1.8				
200L8/6B	15	208572-**A	730	87	0.65	40.30	5.0	196.23	1.8	1.8	0.58868	300	80	
	20		980	88	0.76	45.44	6.0	194.90	2	1.8				
225M8/6A	24	228371-**A	730	89	0.81	50.58	5.0	313.97	1.5	1.8	0.82047	380	82	
	30		975	89	0.87	58.87	6.0	293.85	1.5	1.8				
160M12/6A	2.6	168391-**A	480	74	0.46	11.61	4.0	51.73	1.2	1.8	0.09629	120	71	
	5		970	84	0.76	11.90	6.0	49.23	1.4	1.8				
160L12/6A	3.7	168591-**A	480	76	0.46	16.08	4.0	73.61	1.2	1.8	0.13030	137	75	
	7		970	85	0.79	15.84	6.0	68.92	1.4	1.8				
180L12/6A	5.5	188591-**A	490	79	0.54	19.59	4.0	107.19	1.3	1.8	0.27033	196	75	
	10		970	86	0.86	20.54	6.0	98.45	1.3	1.8				
200L12/6A	7.5	208591-**A	485	83	0.56	24.52	4.0	147.68	1.5	1.8	0.47842	258	78	
	13		970	87	0.86	26.40	6.0	127.99	1.5	1.8				
200L12/6B	9	208592-**A	485	83	0.57	28.90	4.0	177.22	1.5	1.8	0.58451	299	78	
	15		970	87	0.87	30.11	6.0	147.68	1.5	1.8				
225M12/6A	12	228391-**A	490	85	0.61	35.16	4.0	233.88	1.5	1.8	0.65971	319	78	
	20		970	88	0.87	39.69	6.0	196.91	1.5	1.8				
250M12/6A	15	258391-**A	490	86	0.63	42.06	4.0	292.35	1.5	1.8	1.02705	425	81	
	24		980	89	0.87	47.09	6.0	233.88	1.5	1.8				
280S12/6A	20	288191-**A	490	88	0.63	54.81	4.0	389.80	1.5	1.8	1.59693	524	81	
	30		980	89	0.87	58.87	6.0	292.35	1.5	1.8				
280M12/6A	24	288391-**A	490	88	0.65	63.75	4.0	467.76	1.5	1.8	1.91104	567	81	
	37		980	89	0.87	72.60	6.0	360.56	1.5	1.8				
100L6/4/2A	0.75	109521-**A	970	67	0.65	2.62	5.5	7.38	1.8	1.8	0.00878	39	79	
	1.3		1460	72	0.75	3.66	6.0	8.50	1.6	1.8				
	1.8		2920	71	0.85	4.53	7.0	5.89	1.6	1.8				

B
380V 50Hz

其他电压频率（最大值，690V）可通过添加VC002，VC209实现。（VC定义请见后页VC适用表）

Other rated voltage connection or frequency(Max,690V)can be used with VC002 or VC209,(The meaning of Variant code can be referred to Variant Code List)

电机技术数据表 Technical Data Table

IP55-IC411

Insulation class F
temperature rise class B

380V50Hz															
Type designation	Output (kW)	Product code	Speed r/min	Efficiency Full load 100% η	Power factor $\cos\phi$	Current			Torque			Moment of inertia $J=1/4GD^2$ kgm^2	Weight kg	Sound pressur level Lp dB(A)	
						I_N A	I_s I_N	I_{MAX} I_N	T_N Nm	T_s T_N	T_{MAX} T_N				
M2QA 112M6/4/2A	1.1	2QAD 119321-**A	970	73	0.65	3.52	5.5	10.83	1.7	1.8	0.01289	45	79		
	2		1460	74	0.81	5.07	6.0	13.08	1.4	1.8					
	2.4		2920	74	0.85	5.80	7.0	7.85	1.6	1.8					
132S6/4/2A	1.8	139121-**A	960	75	0.71	5.14	5.5	17.91	1.4	1.8	0.02728	61	83		
	2.6		1460	78	0.83	6.10	6.0	17.01	1.3	1.8					
	3		2900	71	0.87	7.38	7.0	9.88	1.7	1.8					
132M6/4/2A	2.2	139321-**A	960	77	0.72	6.03	5.5	21.89	1.3	1.8	0.03151	70	83		
	3.3		1440	80	0.84	7.46	6.0	21.89	1.3	1.8					
	4		2880	76	0.91	8.79	7.0	13.26	1.7	1.8					
132M6/4/2B	2.6	139322-**A	960	80	0.72	6.86	5.5	25.86	1.5	1.8	0.04015	83	83		
	4		1470	80	0.84	9.04	6.0	25.99	1.4	1.8					
	5		2880	77	0.91	10.84	7.0	16.58	1.7	1.8					
160M6/4/2A	3.7	169321-**A	980	82	0.72	9.52	5.5	36.06	1.5	1.8	0.06902	116	87		
	5		1475	81	0.84	11.17	6.0	32.37	1.3	1.8					
	6		2950	76	0.91	13.18	7.0	19.42	1.4	1.8					
160L6/4/2A	4.5	169521-**A	980	83	0.72	11.44	5.5	43.85	1.5	1.8	0.08521	128	87		
	7		1475	83	0.85	15.08	6.0	45.32	1.2	1.8					
	9		2950	79	0.72	18.81	7.0	29.14	1.3	1.8					
112M8/4/2A	0.65	119341-**A	720	59	0.63	2.66	4.5	8.62	1.4	1.8	0.01289	44	79		
	2		1460	74	0.81	5.07	6.0	13.08	1.3	1.8					
	2.4		2920	74	0.85	5.80	7.0	7.85	1.2	1.8					
132S8/4/2A	1	139141-**A	720	69	0.61	3.61	4.5	13.26	1.4	1.8	0.02728	61	83		
	2.6		1460	78	0.83	6.10	6.0	17.01	1.2	1.8					
	3		2880	74	0.87	7.08	7.0	9.95	1.4	1.8					
132M8/4/2A	1.3	139341-**A	720	71	0.61	4.56	4.5	17.24	1.5	1.8	0.37988	80	83		
	3.7		1460	80	0.84	8.37	6.0	24.20	1.3	1.8					
	4.5		2880	75	0.91	10.02	7.0	14.92	1.4	1.8					
160M8/4/2A	2.2	169341-**A	740	75	0.59	7.55	4.5	28.39	1.4	1.8	0.06902	116	87		
	5		1475	81	0.84	11.17	6.0	32.37	1.3	1.8					
	6		2950	76	0.91	13.18	7.0	19.42	1.4	1.8					
160L8/4/2A	2.8	169541-**A	740	77	0.60	9.21	4.5	36.14	1.3	1.8	0.08521	129	87		
	7		1475	83	0.85	15.08	6.0	45.32	1.2	1.8					
	9		2950	79	0.92	18.81	7.0	29.14	1.3	1.8					
112M8/6/4A	0.85	119361-**A	730	62	0.56	3.72	5.5	11.12	1.7	1.8	0.01794	46	74		
	1		960	68	0.73	3.06	6.5	9.95	1.3	1.8					
	1.5		1440	75	0.86	3.53	7.0	9.95	1.5	1.8					
132S8/6/4A	1.1	139161-**A	730	68	0.60	4.10	5.5	14.39	1.4	1.8	0.04051	60	74		
	1.5		975	74	0.73	4.22	6.5	14.69	1.3	1.8					
	1.8		1460	78	0.87	4.03	7.0	11.77	1.3	1.8					
132M8/6/4A	1.5	139361-**A	730	71	0.62	5.18	5.5	19.62	1.3	1.8	0.05316	75	74		
	2		975	77	0.73	5.41	6.5	19.59	1.5	1.8					
	2.2		1460	79	0.87	4.86	7.5	14.39	1.4	1.8					
132M8/6/4B	1.8	139362-**A	730	72	0.62	6.13	5.5	23.55	1.5	1.8	0.05965	82	74		
	2.6		975	78	0.74	6.84	6.5	25.47	1.5	1.8					
	3		1460	80	0.87	6.55	7.0	19.62	1.5	1.8					
160M8/6/4A	3.3	169361-**A	730	79	0.62	10.24	5.5	43.17	1.7	1.8	0.09630	121	78		
	4		980	81	0.76	9.87	6.5	38.98	1.4	1.8					
	5.5		1460	83	0.87	11.57	7.0	35.98	1.5	1.8					
160L8/6/4A	4.5	169561-**A	730	80	0.62	13.78	5.5	58.87	1.6	1.8	0.13030	137	78		
	6		980	83	0.76	14.75	6.5	58.87	1.6	1.8					
	7.5		1460	84	0.87	15.59	7.0	49.06	1.5	1.8					

B
380V 50Hz

其他电压频率（最大值，690V）可通过添加VC002，VC209实现。（VC定义请见后页VC适用表）

Other rated voltage connection or frequency(Max,690V)can be used with VC002 or VC209,(The meaning of Variet code can be referred to Variant Code List)

轴承型号，接线盒出线孔尺寸 Type of Bearing Cable Entry

电机规格	轴承型号 Type of bearing				接线盒出线孔 Cable entry	
	M2QA(NSK)		QAD(C)		M2QA	QAD
	前 D-end	后 N-end	前 D-end	后 N-end		
80M	6204/C3	6204/C3	6204/C3	6204/C3	2-M25x1.5	M24x1.5
90S	6205/C3	6205/C3	6205/C3	6205/C3	2-M25x1.5	M24x1.5
90L	6205/C3	6205/C3	6205/C3	6205/C3	2-M25x1.5	M24x1.5
100L	6206/C3	6206/C3	6206/C3	6206/C3	2-M32x1.5	M30x2
112M	6207/C3	6206/C3	6207/C3	6206/C3	2-M32x1.5	M30x2
132S	6208/C3	6207/C3	6208/C3	6207/C3	2-M32x1.5	M30x2
132M	6208/C3	6207/C3	6208/C3	6207/C3	2-M32x1.5	M30x2
160M	6309/C3	6209/C3	6209/C3	6209/C3	2-M40x1.5	M36x2
160L	6309/C3	6209/C3	6209/C3	6209/C3	2-M40x1.5	M36x2
180M	6310/C3	6210/C3	6310/C3	6210/C3	2-M40x1.5	M36x2
180L	6310/C3	6210/C3	6310/C3	6210/C3	2-M40x1.5	M36x2
200L	6312/C3	6212/C3	6312/C3	6212/C3	2-M50x1.5	M48x2
225S	6313/C3	6213/C3	6313/C3	6213/C3	2-M50x1.5	M48x2
225M	6313/C3	6213/C3	6313/C3	6213/C3	2-M50x1.5	M48x2
250M	6314/C3	6214/C3	6314/C3	6214/C3	2-M63x1.5	2-M63x1.5
280			6316/C3	6316/C3		2-M63x1.5
280 4/2P			6316/C4	6316/C4		2-M63x1.5

注：下表列出了标准配置下的单列深沟球轴承。71-225标配封闭轴承，250-355标配开启式轴承。
Note: The motors are normally fitted with single-row deep groove ball bearings as listed in the table below. Close-type bearing is provided as standard for 71-255, open-type bearing for 250-355.

电机铭牌 Rating Plate

ABB		ABB Motors			
3~Mot. M2QA112M6-4A		IEC60034-1			
2QA2118341-ADA		Cl. F	IP 55		
6207DDU/C3		6206DDU/C3			
Date 2009.8					
V	Hz	r/min	kW	cosφ	A
400 Y	50	950	1.0	0.68	3.08
400 Y	50	1425	3.0	0.85	6.41
					45 kg
No. 3GC09500030030003021					

ABB		ABB Motors					
3~motor		M2QA160M4/2A					
IEC 160M 42							
S1		No.3GC09500030039001029					
Cert.no.		Ins.cl. F	IP 55				
V	Hz	kW	r/min	A	cosφ	IA/IN	tE/s
400 Y	50	2.0	1460	5.02	0.68		
400YY	50	10	2925	18.43	0.90		
Prod.code 2QA2168311-ADA							
6309ZZ/C3		6209ZZ/C3		104 kg			
Date 2009.8		IEC 60034-1					

电机技术数据表 Technical Data Table

IP55-IC411

Insulation class F
Temperature rise class B

380V50Hz														
Type designation	Output (kW)	Product code	Speed r/min	Efficiency Full load 100% η	Power factor $\cos\phi$	Current			Torque			Moment of inertia $J=1/4GD^2$ kgm ²	Weight kg	Sound pressure level Lp dB(A)
						I_N A	I_s I_N	I_{sN}	T_N Nm	T_s T_N	T_{MAX} T_N			
M2QA 180L8/6/4A	7	2QAD 189561-**A	725	81	0.65	20.20	6.5	92.21	1.6	1.8	0.27033	197	82	
	9		980	83	0.80	20.59	7.0	87.70	1.5	1.8				
	12		1450	84	0.90	24.12	7.0	79.03	1.4	1.8				
200L8/6/4A	10	209561-**A	730	85	0.72	24.83	6.5	130.82	1.6	1.8	0.58451	299	82	
	13		980	86	0.81	28.35	7.0	126.68	1.5	1.8				
	17		1460	86	0.90	33.37	7.0	111.20	1.4	1.8				
225S8/6/4A	14	229161-**A	730	86	0.70	35.33	6.5	183.15	1.6	1.8	0.78781	368	84	
	18.5		980	87	0.81	39.89	7.0	180.28	1.6	1.8				
	24		1460	87	0.90	46.57	7.0	156.99	1.4	1.8				
225M8/6/4A	17	229361-**A	730	87	0.70	42.41	6.5	222.40	1.6	1.8	0.88477	396	84	
	22		980	87	0.85	45.20	7.0	214.39	1.6	1.8				
	28		1460	87	0.90	54.33	7.0	183.15	1.4	1.8				
250M8/6/4A	24	259361-**A	740	88	0.75	55.25	6.5	309.73	1.5	1.8	1.50755	552	84	
	26		980	88	0.85	52.81	7.0	253.37	1.6	1.8				
	34		1480	88	0.92	63.81	7.0	219.39	1.4	1.8				
280S8/6/4A	30	289161-**A	740	89	0.75	68.29	6.5	387.16	1.5	1.8	2.44334	679	86	
	34		980	89	0.86	67.49	7.0	331.33	1.6	1.8				
	42		1480	89	0.92	77.94	7.0	271.01	1.4	1.8				
280M8/6/4A	34	289361-**A	740	89	0.75	77.39	6.5	438.78	1.4	1.8	2.80528	729	86	
	37		980	89	0.86	73.45	7.0	360.56	1.5	1.8				
	50		1480	89	0.92	92.78	7.0	322.64	1.4	1.8				
180L12/8/6/4A	3.3	189581-**A	490	72	0.55	12.66	5.0	64.32	1.6	1.8	0.30462	215	82	
	5		735	79	0.62	15.51	6.5	64.97	1.5	1.8				
	6.5		970	82	0.88	13.69	6.5	63.99	1.3	1.8				
	9		1470	83	0.89	18.51	7.0	58.47	1.3	1.8				
200L12/8/6/4A	4.5	209581-**A	490	74	0.56	16.50	5.0	87.70	1.3	1.8	0.54208	282	82	
	7		730	81	0.67	19.60	6.5	91.58	1.3	1.8				
	8		975	83	0.88	16.64	6.5	78.36	1.3	1.8				
	11		1480	84	0.88	22.61	7.0	70.98	1.3	1.8				
200L12/8/6/4B	5.5	209582-**A	490	75	0.56	19.90	5.0	107.19	1.3	1.8	0.58451	298	82	
	8		730	81	0.67	22.40	6.5	104.66	1.3	1.8				
	10		970	83	0.88	20.80	6.5	98.45	1.3	1.8				
	13		1470	84	0.88	26.72	7.0	84.46	1.3	1.8				
225M12/8/6/4A	7	229381-**A	470	81	0.63	20.84	5.0	142.23	1.6	1.8	0.82047	371	82	
	11		730	84	0.72	27.63	6.5	143.90	1.6	1.8				
	13		970	85	0.88	26.41	6.5	127.99	1.5	1.8				
	20		1430	86	0.90	39.26	7.0	133.57	1.3	1.8				
250M12/8/6/4A	9	259381-**A	490	82	0.63	26.47	5.0	175.41	1.6	1.8	1.33041	501	84	
	14		740	85	0.73	34.28	6.5	180.68	1.6	1.8				
	16		980	85	0.88	32.50	6.5	155.92	1.5	1.8				
	26		1480	87	0.92	49.36	7.0	167.77	1.3	1.8				
280S12/8/6/4A	11	289181-**A	490	83	0.63	31.96	5.0	214.39	1.6	1.8	2.22806	563	84	
	18.5		740	87	0.75	43.08	6.5	238.75	1.6	1.8				
	20		980	85	0.88	40.63	6.5	194.92	1.5	1.8				
	34		1480	87	0.92	64.54	7.0	219.39	1.3	1.8				
280M12/8/6/4A	13	289381-**A	490	84	0.63	37.32	5.0	253.37	1.7	1.8	2.66176	612	86	
	22		740	87	0.75	51.23	6.5	283.92	1.7	1.8				
	24		980	85	0.88	48.75	6.5	233.88	1.6	1.8				
	40		1480	88	0.92	75.07	7.0	258.11	1.5	1.8				

B
380V 50Hz

其他电压频率（最大值，690V）可通过添加VC002，VC209实现。（VC定义请见后页VC适用表）

Other rated voltage connection or frequency(Max,690V)can be used with VC002 or VC209,(The meaning of Variant code can be referred to Variant Code List)

M2QA变极变速系列三相异步电动机变量代码 (简称M2变极变速VC)

代码/Code	变量/Variant	Frame Size													
		71	80	90	100	112	132	160	180	200	225	250	280	315	355
管理/Administration															
531	海运包装 Sea freight packing	NA	NA	NA	NA	NA	NA	P	P	P	P	P	P	R	R
平衡/Balancing															
423	无键平衡 Balanced without key.	P	P	P	P	P	P	P	P	P	P	P	P	R	R
424	全键平衡 Full key balancing.	P	P	P	P	P	P	P	P	P	P	P	P	R	R
轴承与润滑/Bearings and Lubrication															
036	轴承装运锁 Transport lock for bearings.	NA	NA	NA	NA	NA	P	P	P	P	P	P	P	R	R
037	D端圆柱滚子轴承 Roller bearing at D-end.	NA	NA	NA	NA	NA	R	R	R	R	R	P	P	P	P
039	耐低温油脂 Cold resistant grease.	P	P	P	P	P	P	P	P	P	P	P	P	R	R
040	耐高温油脂 Heat resistant grease.	P	P	P	P	P	P	P	P	P	P	P	P	R	R
041	通过注油孔对轴承加油 Bearings regreasable via grease nipples.	NA	NA	NA	NA	R	R	R	R	R	R	S	S	R	R
058	D端角接触球轴承, 轴向力 远离轴承 Angular contact bearing at D-end, shaft force away from bearing.	NA	NA	NA	NA	NA	NA	R	R	R	R	R	R	R	R
059	N端角接触球轴承, 轴向指 向离轴承 Angular contact bearing at N-end, shaft force towards bearing.	NA	NA	NA	NA	NA	NA	R	R	R	R	R	R	R	R
060	D端角接触球轴承, 轴向指 向离轴承 Angular contact bearing at D-end, shaft force towards bearing.	NA	NA	NA	NA	NA	NA	R	R	R	R	R	R	R	R
061	N端角接触球轴承, 轴向指 向离轴承 Angular contact bearing at N-end, shaft force away from bearing.	NA	NA	NA	NA	NA	NA	R	R	R	R	R	R	R	R
043	SPM震动测量接头 SPM compatible nipples for vibration measurement.	NA	NA	NA	NA	R	P	P	P	P	P	P	P	R	R
130	轴承Pt100 (3线) Pt100 3-wire in bearing.	NA	NA	NA	NA	NA	NA	R	R	R	R	R	R	R	R
195	全封闭轴承 Bearings greased for life.	S	S	S	S	S	S	S	S	S	S	NA	NA	NA	NA
798	不锈钢注油嘴 Stainless steel grease nipples.	NA	NA	NA	NA	R	R	R	R	R	R	P	P	R	R
部门标准设计/Branch standard designs															
209	非标电压或频率 (特殊绕组) Non-standard voltage or frequency.(special winding)	R	R	R	R	R	R	R	R	R	R	R	R	R	R
168	仅涂底漆 Primer paint only.	P	P	P	P	P	P	P	P	P	P	P	P	R	R
178	不锈钢/耐酸螺栓 Stainless steel/acid proof bolts.	R	R	R	R	R	R	R	R	R	R	R	R	R	R
396	用于环境温度-20°C~-40°C 的电机, 带空间加热带 (代码450/451必须) Motor designed for ambient temperature -20°C~-40°C, with space heaters(code 450/451 must be added).	P	P	P	P	P	P	P	P	P	P	P	P	R	R
425	防腐蚀定子和转子 Corrosion protected stator and rotor core.	P	P	P	P	P	P	P	P	P	P	R	R	R	R

S=在标准情况下包含
R=根据需要, 技术确认
NA=不适用
P=根据需要, 直接排产

S=Included as standard
R=On request
NA=Not applicable
P=Applicable

M2QA变极变速系列三相异步电动机变量代码 (简称M2变极变速VC)

代码/Code	变量/Variant	Frame Size													
		71	80	90	100	112	132	160	180	200	225	250	280	315	355
部门标准设计/Branch standard designs															
117	两个速度适用的Y/D启动接线(双速电机绕组) Terminals for Y/D start at both speeds (two speed windings).	R	R	R	R	R	R	R	R	R	R	R	R	R	R
118	高速度适用的Y/D启动接线(双速电机绕组) Terminals for Y/D start at high speed (two speed windings).	R	R	R	R	R	R	R	R	R	R	R	R	R	R
119	低速度适用的Y/D启动接线(双速电机绕组) Terminals for Y/D start at low speed (two speed windings).	R	R	R	R	R	R	R	R	R	R	R	R	R	R
冷却系统/Cooling system															
068	轻金属风扇(合金) Light alloy metal fan.	P	P	P	P	P	P	P	P	P	P	P	P	R	R
075	冷却方式IC418(无风扇) Cooling method IC418 (without fan).	P	P	P	P	P	P	P	P	P	P	P	P	R	R
文件材料/Documentation															
141	配外形图 Binding dimension drawing.	P	P	P	P	P	P	P	P	P	P	P	P	R	R
排水孔/Drain holes															
065	塞紧现有排水孔 Plugged existing drain holes.	S	S	S	S	S	S	S	S	S	S	P	P	R	R
接地螺栓/Earthing Bolt															
067	外部接地螺栓 External earthing bolt.	P	P	P	P	P	P	P	P	P	P	S	S	R	R
加热元件/Heating elements															
450	加热带100-120V Heating elements,100-120V	P	P	P	P	P	P	P	P	P	P	P	P	R	R
451	加热带200-240V Heating elements,200-240V	P	P	P	P	P	P	P	P	P	P	P	P	R	R
绝缘系统/Insulation system															
014	H级绝缘绕组 Winding insulation class H.	P	P	P	P	P	P	P	P	P	P	P	P	R	R
999	加强绝缘 I Special winding insulation I.	P	P	P	P	P	P	P	P	P	P	P	P	R	R
999	加强绝缘 II Special winding insulation II.	P	P	P	P	P	P	P	P	P	P	P	P	R	R
安装方式/Mounting arrangements															
008	IM2101底脚/法兰安装, IEC法兰, 由IM1001派生 (B3派生出B34) IM2101 foot/flange mounted, IEC flange, from IM1001 (B34 from B3)	P	P	P	P	P	P	P	NA	NA	NA	NA	NA	NA	NA
009	IM2001底脚/法兰安装, IEC法兰, 由IM1001派生 (B3派生出B35) IM2001 foot/flange mounted, IEC flange, from IM1001 (B35 from B3)	P	P	P	P	P	P	P	P	P	P	P	P	R	R
047	IM3601法兰安装, IEC法兰, 由IM3001派生 (B5派生出B14) IM3601 flange mounted, IEC flange, from IM3001 (B14 from B5)	P	P	P	P	P	P	P	NA	NA	NA	NA	NA	NA	NA

S=在标准情况下包含
R=根据需要, 技术确认
NA=不适用
P=根据需要, 直接排产

S=Included as standard
R=On request
NA=Not applicable
P=Applicable

M2QA变极变速系列三相异步电动机变量代码 (简称M2变极变速VC)

代码/Code	变量/Variant	Frame Size													
		71	80	90	100	112	132	160	180	200	225	250	280	315	355
管理/Administration															
066	非标安装方式(请指定IM xxx) (除B3(1001)、B5(30010)、 B14(3601), IM B35(2001) &IM B34)(2101)外的其它安 装型式须在定单中注明 Modified for specified mounting position differing from IM B3(1001), IM B5 (3001), B14(3601), IM B35 (2001) & IM B34(2101).	P	P	P	P	P	P	P	P	P	P	P	P	P	P
999 ¹⁾	非标安装方式(请指定IM xxx) (除B3(1001)、B5(30010)、 B14(3601), IM B35(2001) &IM B34)(2101)外的其它安 装型式须在定单中注明). 铸铁需加强 Modified for specified mounting position differing from IM B3(1001),IM B5(3001), B14(3601), IM B35(2001) &IM B34(2101),strengthen the casting)	NA	NA	NA	NA	NA	NA	NA	P	P	P	P	P	P	P
999	大法兰 (C***) B14 big flange	P	P	P	P	P	NA	NA	NA	NA	NA	NA	NA	NA	NA
喷漆/Painting															
114	特殊油漆颜色, 标准等级 Special paint colour,standard grade.	R	R	R	R	R	R	R	R	R	R	R	R	R	R
106	喷涂厚度=80µm Paint thickness =80µm.	R	R	R	R	R	R	R	R	R	R	R	R	R	R
109	喷涂厚度=120µm Paint thickness =120µm.	R	R	R	R	R	R	R	R	R	R	R	R	R	R
110	喷涂厚度=160µm Paint thickness =160µm.	R	R	R	R	R	R	R	R	R	R	R	R	R	R
防护/Protection															
005	金属防雨罩, 立式电机, 轴伸向下 Metal protective roof,vertical motor,shaft down.	P	P	P	P	P	P	P	P	P	P	P	P	P	P
072	D端径向密封 Radial seal at D-end.	P	P	P	P	P	P	P	P	P	P	S	S	S	S
158	防护等级IP65 Degree of protection IP65	P	P	P	P	P	P	P	P	P	P	P	P	P	P
403	防护等级IP56 Degree of protection IP56	P	P	P	P	P	P	P	P	P	P	P	P	P	P
784	D端伽玛密封 Gamma-seal at D-end.	S	S	S	S	S	S	S	S	S	S	NA	NA	NA	NA
铭牌和指示牌/Rating & instuction plates															
002	重敲铭牌电压、频输出、连 续工作制 Restamping voltage,frequency and output,continuous duty.	R	R	R	R	R	R	R	R	R	R	R	R	R	R
095	重刻输出功率(相同电压、 频率下), 间歇工作制 Restamping output(maintained voltage,frequency),intermittent duty.	R	R	R	R	R	R	R	R	R	R	R	R	R	R
135	安装额外不锈钢指示牌 Mounting of additional identification plate,stainless.	P	P	P	P	P	P	P	P	P	P	P	P	P	P
轴和转子/Shaft & rotor															
070	D端特殊轴伸, 标准材料 Special shaft extension at D-end,shandard shaft material.	P	P	P	P	P	P	P	P	P	P	P	P	P	P
069	标准双出轴 Two shaft extension as per basic catalogue.	R	R	R	R	R	R	R	R	R	R	R	R	R	R

1)安装型为: B6、B7、B8、V15、V3、V35、V5、V6
1)Mounting arrangements:B6、B7、B8、V15、V3、V35、V5、V6

S=在标准情况下包含
R=根据需要, 技术确认
NA=不适用
P=根据需要, 直接排产

S=Included as standard
R=On request
NA=Not applicable
P=Applicable

M2QA变极变速系列三相异步电动机变量代码 (简称M2变极变速VC)

代码/Code	变量/Variant	Frame Size													
		71	80	90	100	112	132	160	180	200	225	250	280	315	355
轴和转子/Shaft & rotor															
164	闭口键槽轴伸 Shaft extension with closed key-way.	R	R	R	R	R	R	R	R	R	R	R	R	R	R
165	开口键槽轴伸 Shaft extension with open key-way.	S	S	S	S	S	S	S	S	S	S	S	S	R	R
标准和规范/Standards and Regulations															
115	符合ISO 12944-5:2007的 喷漆系统C4M Painting system C4M acc. To ISO 12944-5:2007.	R	R	R	R	R	R	R	R	R	R	R	R	R	R
754	符合ISO 12944-5:2007的 喷漆系统C5M Painting system C5M acc. To ISO 12944-5:2007.	R	R	R	R	R	R	R	R	R	R	R	R	R	R
定子绕组温度传感器/Stator winding temperature sensors															
120	定子绕组安装KTY 84-130 (每相1个) KTY 84=130 (1 per phase) in stator winding.	R	R	R	R	R	R	R	R	R	R	R	R	R	R
121	定子绕组安装双金属温度开 关(NCC,3个串联,130°C) Bimetal detectors,break type (NCC),(3 in series),130°C,in stator winding.	P	P	P	P	P	P	P	P	P	P	P	P	R	R
122	定子绕组安装双金属温度开 关(NCC,3个串联,150°C) Bimetal detectors,break type (NCC),(3 in series),150°C,in stator winding.	P	P	P	P	P	P	P	P	P	P	P	P	R	R
123	定子绕组安装双金属温度开 关(NCC,3个串联,170°C) Bimetal detectors,break type (NCC),(3 in series),170°C,in stator winding.	P	P	P	P	P	P	P	P	P	P	P	P	R	R
124	定子绕组安装双金属温度开 关(NCC,3个串联, 140°C) Bimetal detectors,break type (NCC),(3 in series),140°C,in stator winding.	P	P	P	P	P	P	P	P	P	P	P	P	R	R
125	定子绕组安装双金属温度开 关(NCC,2×3个串联,150°C) Bimetal detectors,break type (NCC),(2×3 in series),150°C, in stator winding.	P	P	P	P	P	P	P	P	P	P	P	P	R	R
127	定子绕组安装双金属温度开 关(NCC,3个串联,130°C以及 3个串联, 150°C) Bimetal detectors,break type (NCC),(3 in series 130°C&3 in series 150°C),in stator winding.	P	P	P	P	P	P	P	P	P	P	P	P	R	R
435	定子绕组安装PTC-热敏电阻 (3个串联),130°C PTC-thermistors(3 in series), 130°C in stator winding.	P	P	P	P	P	P	P	P	P	P	P	P	R	R
436	定子绕组安装PTC-热敏电阻 (3个串联),150°C PTC-thermistors(3 in series), 150°C in stator winding.	P	P	P	P	P	P	P	P	P	P	P	P	R	R
437	定子绕组安装PTC-热敏电阻 (3个串联),170°C PTC-thermistors(3 in series), 170°C in stator winding.	P	P	P	P	P	P	P	P	P	P	P	P	R	R
439	定子绕组安装PTC-热敏电阻 (2×3个串联), 150°C PTC-thermistors(2×3 in series), 150°C, in stator winding.	P	P	P	P	P	P	P	P	P	P	P	P	R	R

S=在标准情况下包含
R=根据需要, 技术确认
NA=不适用
P=根据需要, 直接排产

S=Included as standard
R=On request
NA=Not applicable
P=Applicable

M2QA变极变速系列三相异步电动机变量代码 (简称M2变极变速VC)

代码/Code	变量/Variant	Frame Size													
		71	80	90	100	112	132	160	180	200	225	250	280	315	355
定子绕组温度传感器/Stator winding temperature sensors															
439	定子绕组安装PTC-热敏电阻 (2×3个串联), 150°C PTC-thermistors(2×3 in series), 150°C, in stator winding.	P	P	P	P	P	P	P	P	P	P	P	P	R	R
440	定子绕组安装PTC-热敏电阻 (3个串联, 110°C以及3个串联, 130°C) PTC-thermistors(3 in series 110°C & 3 in series 130°C),in stator winding.	P	P	P	P	P	P	P	P	P	P	P	P	R	R
441	定子绕组安装PTC-热敏电阻 (3个串联, 130°C以及3个串联, 150°C) PTC-thermistors(3 in series 130°C & in series 150°C),in stator winding.	P	P	P	P	P	P	P	P	P	P	P	P	R	R
442	定子绕组安装PTC-热敏电阻 (3个串联, 150°C以及3个串联, 170°C) PTC-thermistors(3 in series 150°C & 3 in series 170°C), in stator winding.	P	P	P	P	P	P	P	P	P	P	P	P	R	R
445	定子绕组安装PT100(2线), 每相1个 PT100 2-wire in stator winding, 1 per phase.	P	P	P	P	P	P	P	P	P	P	P	P	R	R
446	定子绕组安装PT100(2线), 每相2个 PT100 2-wire in stator winding, 2 per phase.	NA	NA	NA	P	P	P	P	P	P	P	P	P	R	R
502	定子绕组安装PT100(3线), 每相1个 PT100 3-wire in stator winding, 1 per phase.	P	P	P	P	P	P	P	P	P	P	P	P	R	R
503	定子绕组安装PT100(3线), 每相2个 PT100 3-wire in stator winding, 2 per phase.	NA	NA	NA	NA	NA	NA	NA	NA	P	P	P	P	R	R
接线盒/Terminal box															
021	左侧接线盒(从D端看) Terminal box LHS(see from D-end).	NA	P	P	P	P	P	P	P	P	P	P	P	R	R
022	电缆进线孔在左侧(从D端看) Cable entry LHS(see from D-end).	P	P	P	P	P	P	P	P	P	P	P	P	R	R
157	接线盒防护等级IP65 Terminal box degree of protection IP65	P	P	P	P	P	P	P	P	P	P	P	P	R	R
180	右侧接线盒(从D端看) Terminal box RHS(see from D-end).	NA	P	P	P	P	P	P	P	P	P	P	P	R	R
376	两个标准塑料葛兰 Two standard plastic cable glands.	P	P	P	P	P	P	P	P	P	P	P	P	R	R
400	4×90度可转动的接线盒 4×90 degr turnable terminal box.	S	S	S	S	S	S	P	P	P	P	P	P	R	R
418	独立的辅助接线盒, 标准材料 Separate terminal box for auxiliaries ,standard material.	NA	NA	NA	NA	NA	NA	R	R	R	R	R	R	R	R
468	电缆进线孔朝D端 Cable entry from D-end.	NA	P	P	P	P	P	P	P	P	P	P	P	R	R
469	电缆进线孔朝N端 Cable entry from N-end.	P	P	P	P	P	P	P	P	P	P	P	P	R	R
704	EMC电缆密封管 EMC cable gland.	R	R	R	R	R	R	R	R	R	R	R	R	R	R
731	2个标准金属电缆密封管 Two standard metal cable glands.	P	P	P	P	P	P	P	P	P	P	P	P	R	R

S=在标准情况下包含
R=根据需要, 技术确认
NA=不适用
P=根据需要, 直接排产

S=Included as standard
R=On request
NA=Not applicable
P=Applicable

M2QA变极变速系列三相异步电动机变量代码 (简称M2变极变速VC)

代码/Code	变量/Variant	Frame Size													
		71	80	90	100	112	132	160	180	200	225	250	280	315	355
接线盒/Terminal box															
738	预留公制单位葛兰 Prepared for metric cable glands.	P	P	P	P	P	P	P	P	P	P	P	P	R	R
740	预留PG单位葛兰 Prepared for PG cable glands.	P	P	P	P	P	P	P	P	P	P	P	P	R	R
137	延长型电缆连接, 散线引出 (无接线板), 压板式, 引出线 长按照标准 Extended cable connected, low terminal box, "Flying leads", factory standard.	R	R	R	R	R	R	R	R	R	R	R	R	R	R
试验/Testing															
145	目录电机的型式试验报告, 400V 50HZ Type test report from a catalogue motor, 400V 50HZ.	P	P	P	P	P	P	P	P	P	P	P	P	R	R
146	指定交货批次内的某一 电机的型式试验及报告 Type test with report for one motor from special delivery batch.	P	P	P	P	P	P	P	P	P	P	P	P	R	R
147	指定交货批次内的某一电机 的型式试验报告, 客户现场见 证 Type test with report for motor from special delivery batch, customer witnessed.	P	P	P	P	P	P	P	P	P	P	P	P	R	R
148	出厂试验报告 Routine test report.	P	P	P	P	P	P	P	P	P	P	P	P	R	R
221	指定交货批次的电机型式试 验和多点负载测试, 并提交 报告 Type test and multi-point load test with report for one motor from specific delivery batch.	P	P	P	P	P	P	P	P	P	P	P	P	R	R
222	指定交货批次的一台电机转 矩转速曲线、型式试验和多 点负载测试, 并提交报告 Type test and multi-point load test with report for one motor from specific delivery batch.	P	P	P	P	P	P	P	P	P	P	P	P	R	R
760	振动等级检测 Vibration level test.	P	P	P	P	P	P	P	P	P	P	P	P	R	R
762	对指定交货批次内的一台 电机进行噪声等级测试 Noise level test for one motor from specific delivery batch.	P	P	P	P	P	P	P	P	P	P	P	P	R	R

S=在标准情况下包含
R=根据需要, 技术确认
NA=不适用
P=根据需要, 直接排产

S=Included as standard
R=On request
NA=Not applicable
P=Applicable

我们为您提供电机及传动单元业务

产品涵盖低压及高压电机、变频器和相关产品

低压电机:M3BP/M2BAX/M3AA/QABP/M2QA/(M)QAEJ/M3JP
M3BJ/M3LJ/M3BC/M3BL/HDP/M2SE/M3GP/M2JA(X)/QAMT

高压电机:NXR/AXR/NMI/AMI/AMD/NMK/AML/AMS/AMZ

变频器:ACS55/ACS150/ACS310/ACS355/ACS380/ACS510

ACS530/ACH531/ACQ531/ACS550/ACS580/ACS880

ACS1000ACS580MV/ACS2000/ACS6000/DCS880/DCS550

机械传动类:联轴器、球轴承、齿轮传动、带座轴承、滑动轴承
齿轮电机和减速机

PLC、软启动器、Ability/Smatr Sensor智能传感器

销售支持

销售机构：南京川投电气有限公司

中国.南京溧水经济开发区秀山中路7号

电话：+86 025-56206366

传真：+86 025-57222171

手机：+86 181-1883-1828

邮箱：abb@abbdianji.com



微信扫码添加我们
官方微信了解更多